

一体式旋转 步进电机(闭环RS485)

28/35/42/57系列

Stepper Motor with Integrated Driver (Closed Loop RS485)

选型手册Catalog



CONTENTS

目录

28 一体式步进驱动器 (闭环 RS485)	01
28 Integrated Stepper Motor Driver (Closed Loop RS485)	
28 旋转一体式步进电机 (闭环 RS485)	05
28 Stepper Motor with Integrated Driver (Closed Loop RS485)	
35 一体式步进驱动器 (闭环 RS485)	06
35 Integrated Stepper Motor Driver (Closed Loop RS485)	
35 旋转一体式步进电机 (闭环 RS485)	10
35 Stepper Motor with Integrated Driver (Closed Loop RS485)	
42 一体式步进驱动器 (闭环 RS485)	11
42 Integrated Stepper Motor Driver (Closed Loop RS485)	
42 旋转一体式步进电机 (闭环 RS485)	17
42 Stepper Motor with Integrated Driver (Closed Loop RS485)	
57 一体式步进驱动器 (闭环 RS485)	18
57 Integrated Stepper Motor Driver (Closed Loop RS485)	
57 旋转一体式步进电机 (闭环 RS485)	24
57 Stepper Motor with Integrated Driver (Closed Loop RS485)	

28 一体式步进驱动器 (闭环 RS485)

28 Integrated Stepper Motor Driver (Closed Loop RS485)

UMLR28

产品概述 / Product Description

UMLR28 一体式 485 总线型闭环步进驱动器是最新推出的带 485 通讯功能的数字式混合步进伺服驱动器，集成了 MODBUS-RTU 标准协议规范，供电接口、IO 输入输出以及通讯接口采用 JST1.25-12P 针座，用户可通过上位机调试软件设置细分、电流、速度、工作模式等多种参数，极大地丰富了产品的实用功能，能够满足大多数场合的应用需要。

UMLR28 integrated 485 bus closed-loop stepper motor driver is the latest digital hybrid one with 485 communication. It integrates MODBUS-RTU standard protocol specifications. The power supply interface, IO input and output ports and communication interface use JST1.25-12P pin sockets. Users can set various parameters such as subdivision, current, speed, working mode, etc. through the controller software, which greatly enriches the practical functions of the product and can meet the application needs of most occasions.

产品特点 / Feature

- 新一代 32 位 DSP 技术，平稳性佳、兼容性强、性价比高
New generation of 32-bit DSP technology, with good stability, strong compatibility and high cost performance
- 支持速度模式、位置模式、多段位置 / 速度模式、JOG+、JOG- 及回原点模式
Support speed mode, position mode, multi-segment position/speed mode, JOG+, JOG- and return to origin mode
- 电流、锁机电流、细分、PI 等参数都可通过主站设置及查询
Current, lock current, subdivision, PI and other parameters can be set and queried through the master station
- 采用 RS485 总线，带隔离，支持标准 MODBUS-RTU 协议
Use RS485 bus, with isolation, support standard MODBUS-RTU protocol.
- 默认通讯地址为 1，更多可通过主站设置
The default communication address is 1, more can be set through the master station
- 3 路光电隔离可编程输入接口，接收外部控制信号，实现驱动器使能，启停，限位等功能
3 road optoelectronic isolation programmable input interface, receive external control signals, meet function for driver enable, start and stop, limit and other functions
- 无光电隔离可编程输出接口，需要可更改
No optoelectronic isolation programmable output interface, can be changed if needed
- 内置微细分，低速平稳性极佳
Built-in micro-segmentation, good work for low-speed and stability
- 具有过压、欠压、缺相等报警保护功能
Overvoltage, undervoltage, phase loss protection
- 纯正弦电流矢量控制有效降低电机发热
Pure sinusoidal current vector control effectively reduces motor heating
- 直流供电，输入电压范围：DC12V~40V
DC power supply, input voltage range: DC12V~40V



应用领域 / Application

适合各种中小型自动化设备和仪器，例如：医疗设备、检测设备、打标机、绘图仪等。满足客户低噪声、低发热、布线方便，抗干扰性更强等要求。

Suitable for various small and medium-sized automation equipment and instruments, such as: medical equipment, testing equipment, marking machines, plotters, etc. Satisfy customers with low noise, low heat, convenient wiring and anti-interference performance stronger requirements.

安装注意事项 / Installation Notes

1) 安装一体式步进驱动器时，切勿敲击电机后端盖，以免影响运行性能，在设计安装尺寸时，需考虑接线端子的大小及布线。
2) 为了保证良好的散热条件，实际安装中必须尽可能预留较大安装间隔，若并排安装多台一体式驱动器，则可安装风扇，使一体式驱动器表面形成较强的空气对流，辅助驱动器散热，保证驱动器在可靠工作温度范围内工作。

1) When installing the integrated stepper driver, do not knock on the end motor to avoid affecting the operating performance. When designing the installation size, the size and wiring of the terminal blocks must be considered.

2) In order to ensure good heat dissipation conditions, a larger installation interval must be reserved as much as possible during actual installation. If multiple integrated drives are installed side by side, fans can be installed to form strong air convection on the surface of the integrated drives to assist in heat dissipation of the drives and ensure that the drives operate within a reliable operating temperature range.

电气指标 / Specifications

说明 Description	UMLR28			
	最小值 Minimum	典型值 Normally	最大值 Max	单位 unit
输出电流 Output Current	0	-	2600	mA
输入电源电压 Input Voltage	12	24	40	VDC
控制信号输入电流 Input Signal Current	7	10	16	mA
绝缘电阻 Insulation Resistance	50	-	-	MΩ

使用环境及参数 / Working Environment

冷却方式 Cooling		自然冷却、风扇散热 Natural cooling, air cooling
使用环境 Working Environment	场合 Environment	不能放在其他发热的设备旁, 要避免粉尘、油雾、腐蚀性气体, 湿度太大及强振动场所, 禁止有可燃气体和导电灰尘 Do not work to other heating equipment. Avoid dust, oil mist, corrosive gases, places with excessive humidity and strong vibrations. No combustible gases are allowed. body and conductive dust
	温度 Temperature	-25-55°C
	湿度 Humidity	40-90%RH
	振动 Vibration	10~55Hz/0.15mm
保存温度 Storage Temperature		-25°C ~65°C

产品接口总体描述 / General Description of Product Interface

UMLR28 一体式 485 总线型闭环步进驱动器的供电接口、IO 输入输出以及通讯接口采用 JST1.25-12P 直针插座, 如下图所示。

The power supply interface, IO input and output port and communication interface of UMLR28 integrated 485 bus closed-loop stepper driver adopt JST1.25-12P straight pin socket, as shown in the figure below.

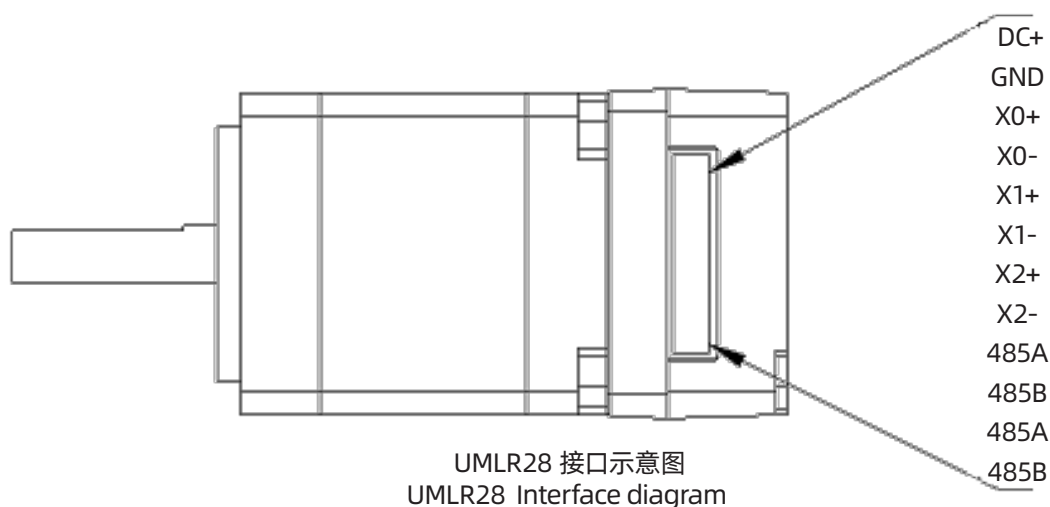

接口功能总体描述 / General Description of Interface Function

名称 Item	说明 Description
GND	供电电源负极 Negative pole of power supply
DC+	供电电源正极, 范围: DC12~40V Positive pole of power supply, range: DC12~40V
X0+ X0-	DC 5V~24V 供电, 接外部输入信号, 可支持差分输入 DC 5V~24V power supply, connect external input signal, support differential input
X1+ X1-	DC 5V~24V 供电, 接外部输入信号, 可支持差分输入 DC 5V~24V power supply, connect external input signal, support differential input
X2+ X2-	DC 5V~24V 供电, 接外部输入信号, 可支持差分输入 DC 5V~24V power supply, connect external input signal, support differential input
485A 485B	485 通讯接口 A B 端 485 communication interface A and B
485A 485B	连接至下一驱动的 485 通讯接口 A B 端 Connect to the 485 communication interface A B end of the next drive

指示灯 / Indicator Light

UMLR28 一体式 485 总线型闭环步进驱动器的指示灯为内缩式贴片 LED, 其基本功能如下表所示。

The indicator light of UMLR28 integrated 485 bus closed-loop stepper driver is a retracted SMD LED, and its basic functions are shown in the following table.

名称 Item	功能 Function	说明 Description
绿色 LED Green LED 红色 LED Red LED	电源、报警指示灯、保存参数功能指示、恢复出厂设置功能指示、拨码状态切换指示; Power supply, alarm indicator light, save parameter function Can indicate, restore factory settings function instructions, Dial status switching indication;	通电正常时绿灯常亮, 红灯熄灭。保存参数、恢复出厂设置、拨码状态发生切换、设备发生异常时, 红绿灯交替闪烁报警, 其闪烁规律查看第六章节; When the power is on normally, the green light is always on and the red light is off. When saving parameters, restoring factory settings, switching the dial status, or abnormal equipment occurs, the red and green lights flash alternately to alarm. For the flashing pattern, please refer to Chapter 6

RS485 通讯接口 / RS485 Communication Interface

UMLR28 一体式 485 总线型闭环步进驱动器的通讯接口采用 JST1.25-12P 的直针插座，如下图所示。

其接口共有 12 个引脚，自上向下对应引脚 1~12，其中引脚 9、10、11、12 用于 RS485 的半双工通讯，引脚 9、10 为一组，接 485 通讯的 A、B 端，引脚 11、12 为一组，驱动内部分别与引脚 9、10 级联，可用于连接至下一驱动设备，其他引脚为其他功能，引脚定义如下表所示。

The communication interface of UMLR28 integrated 485 bus closed-loop stepper driver adopts JST1.25-12P straight pin socket, as shown in the figure below.

The interface has 12 pins in total, corresponding to pins 1 to 12 from top to bottom, of which pins 9, 10, 11, and 12 are used for half-duplex communication of RS485. Pins 9 and 10 are a group, connected to the A and B ends of 485 communication, and pins 11 and 12 are a group. They are cascaded with pins 9 and 10 inside the driver, respectively, and can be used to connect to the next driver device. Other pins have other functions. The pin definitions are shown in the following table.

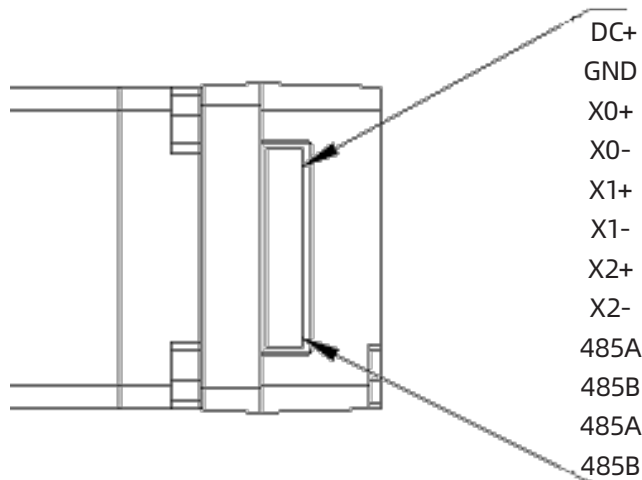

UMLR28 一体式 485 总线型闭环步进驱动器接口示意图
UMLR28 integrated 485 bus closed-loop stepper driver interface diagram

引脚 Pin	定义 Definition
X0+、X0-、X1+、X1-、X2+、X2-	输入 IO 口 Input IO port
485A 485B	485 通讯接口 A B 端 485 communication interface A and B
485A 485B	连接至下一驱动的 485 通讯接口 A B 端 Connect to the 485 communication interface A B end of the next drive

尺寸图 / Dimensions

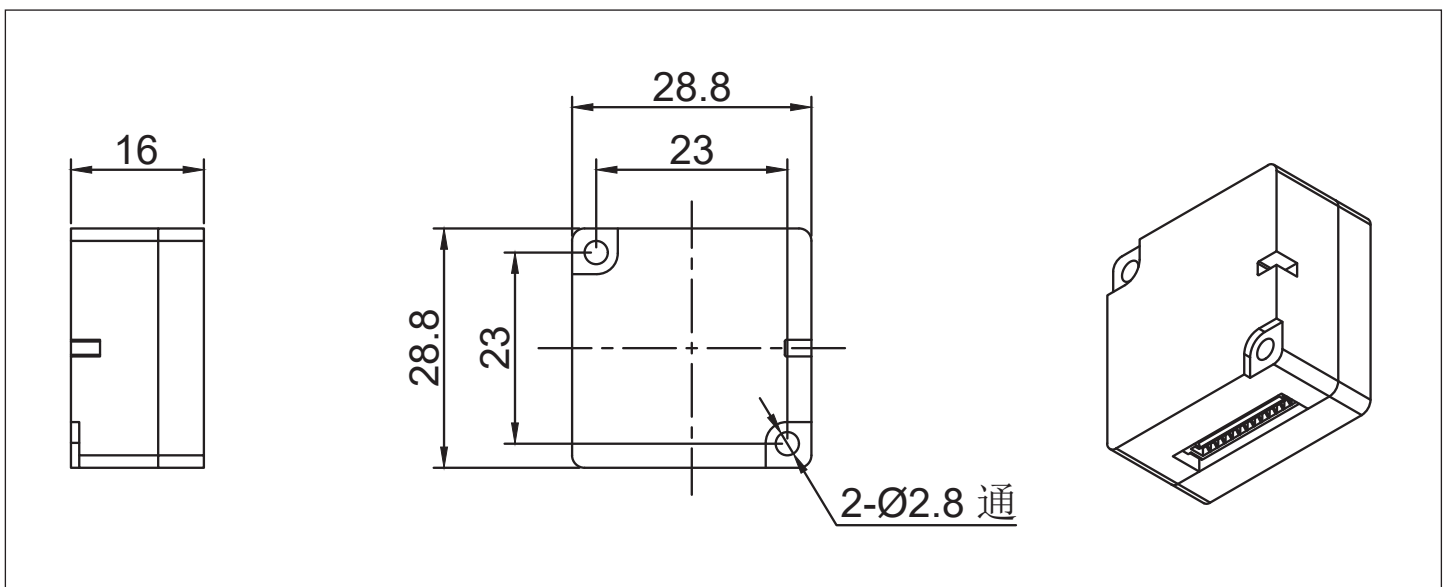

28 旋转一体式步进电机 (闭环 RS485)

28 Stepper Motor with Integrated Driver (Closed Loop RS485)



性能规格书 / Technical Data

Model No.	保持转矩 Holding Torque (mN.m)	额定电流 Rated Current (A)	相电阻 Resistance (Ω)	额定电压 Rated Voltage (V)	转动惯量 Rotor Inertia (g-cm ²)	机身长度 (L) Length(L) (mm)
28HS2401	65	0.67	5.8	3.88	15	32.5
28HS4401	90	0.7	6.5	4.55	25	40
28HS7401	100	0.67	9	6.03	30	52

尺寸图 / Dimensions

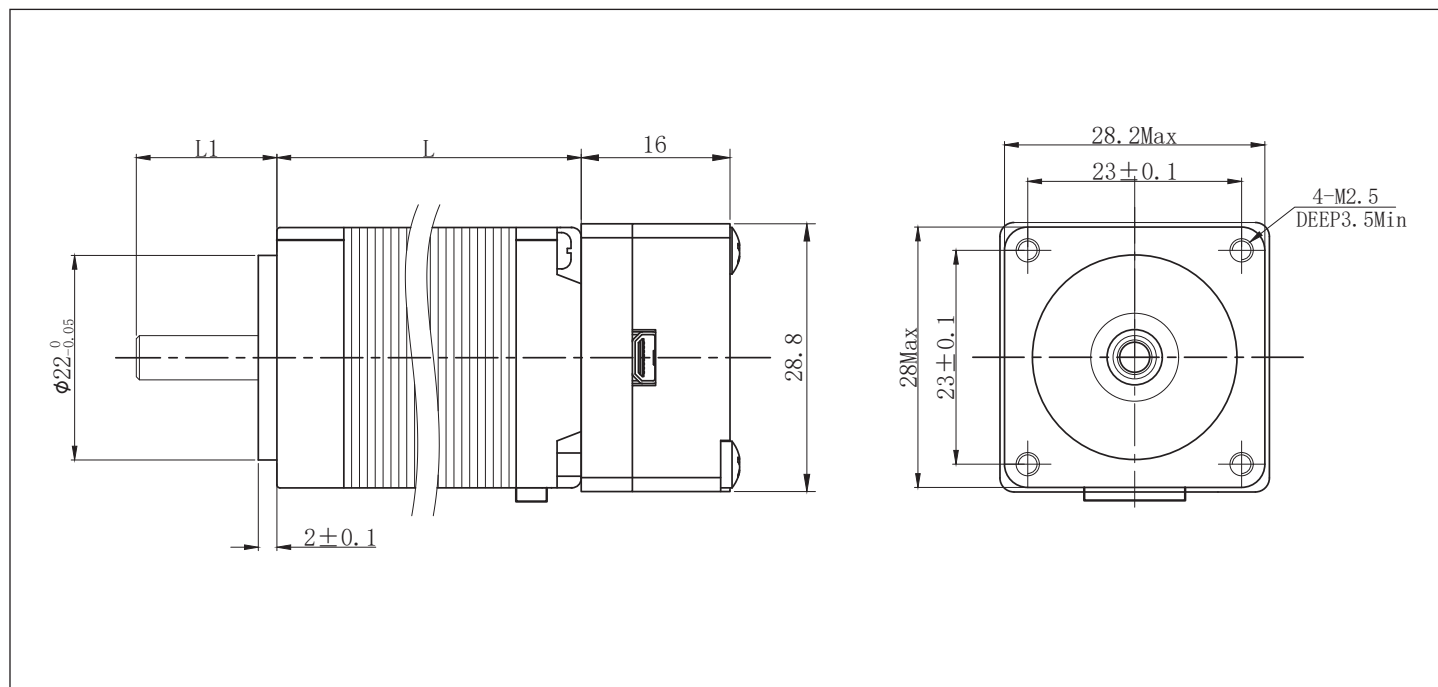

35 一体式步进驱动器 (闭环 RS485)

35 Integrated Stepper Motor Driver (Closed Loop RS485)

UMLR35

产品概述 / Product Description

UMLR35 一体式 485 总线型闭环步进驱动器是最新推出的带 485 通讯功能的数字式混合步进伺服驱动器，集成了 MODBUS-RTU 标准协议规范，供电接口、IO 输入输出以及通讯接口采用 JST1.25-12P 针座，用户可通过上位机调试软件设置细分、电流、速度、工作模式等多种参数，极大地丰富了产品的实用功能，能够满足大多数场合的应用需要。

UMLR35 integrated 485 bus closed-loop stepper motor driver is the latest digital hybrid one with 485 communication. It integrates MODBUS-RTU standard protocol specifications. The power supply interface, IO input and output ports and communication interface use JST1.25-12P pin sockets. Users can set various parameters such as subdivision, current, speed, working mode, etc. through the controller software, which greatly enriches the practical functions of the product and can meet the application needs of most occasions.

产品特点 / Feature

- 新一代 32 位 DSP 技术，平稳性佳、兼容性强、性价比高
New generation of 32-bit DSP technology, with good stability, strong compatibility and high cost performance
- 支持速度模式、位置模式、多段位置 / 速度模式、JOG+、JOG- 及回原点模式
Support speed mode, position mode, multi-segment position/speed mode, JOG+, JOG- and return to origin mode.
- 电流、锁机电流、细分、PI 等参数都可通过主站设置及查询
Current, lock current, subdivision, PI and other parameters can be set and queried through the master station.
- 采用 RS485 总线，带隔离，支持标准 MODBUS-RTU 协议
Use RS485 bus, with isolation, support standard MODBUS-RTU protocol
- 默认通讯地址为 1，更多可通过主站设置
The default communication address is 1, more can be set through the master station
- 3 路光电隔离可编程输入接口，接收外部控制信号，实现驱动器使能，启停，限位等功能
3 road optoelectronic isolation programmable input interface, receive external control signals, meet function for driver enable, start and stop, limit and other functions
- 无光电隔离可编程输出接口，需要可更改
No optoelectronic isolation programmable output interface, can be changed if needed
- 内置微细分，低速平稳性极佳
Built-in micro-segmentation, good work for low-speed and stability
- 具有过压、欠压、缺相等报警保护功能
Overvoltage, undervoltage, phase loss protection
- 纯正弦电流矢量控制有效降低电机发热
Pure sinusoidal current vector control effectively reduces motor heating
- 直流供电，输入电压范围：DC12V~40V
DC power supply, input voltage range: DC12V~40V



应用领域 / Application

适合各种中小型自动化设备和仪器，例如：医疗设备、检测设备、打标机、绘图仪等。满足客户低噪声、低发热、布线方便，抗干扰性更强等要求。

Suitable for various small and medium-sized automation equipment and instruments, such as: medical equipment, testing equipment, marking machines, plotters, etc. Satisfy customers with low noise, low heat, convenient wiring and anti-interference performance stronger requirements.

电气指标 / Specifications

说明 Description	UMLR35			
	最小值 Minimum	典型值 Normally	最大值 Max	单位 unit
输出电流 Output Current	0	-	2600	mA
输入电源电压 Input Voltage	12	24	40	VDC
控制信号输入电流 Input Signal Current	7	10	16	mA
绝缘电阻 Insulation Resistance	50	-	-	MΩ

使用环境及参数 / Working Environment

冷却方式 Cooling		自然冷却、风扇散热 Natural cooling, air cooling
使用环境 Working Environment	场合 Environment	不能放在其他发热的设备旁, 要避免粉尘、油雾、腐蚀性气体, 湿度太大及强振动场所, 禁止有可燃气体和导电灰尘 Do not work to other heating equipment. Avoid dust, oil mist, corrosive gases, places with excessive humidity and strong vibrations. No combustible gases are allowed. body and conductive dust
	温度 Temperature	-25-55°C
	湿度 Humidity	40-90%RH
	振动 Vibration	10~55Hz/0.15mm
保存温度 Storage Temperature		-25°C ~65°C

产品接口总体描述 / General Description of Product Interface

UMLR35 一体式 485 总线型闭环步进驱动器的供电接口、IO 输入输出以及通讯接口采用 JST1.25-12P 直针插座, 如下图所示

The power supply interface, IO input and output port and communication interface of UMLR35 integrated 485 bus closed-loop stepper driver adopt JST1.25-12P straight pin socket, as shown in the figure below.

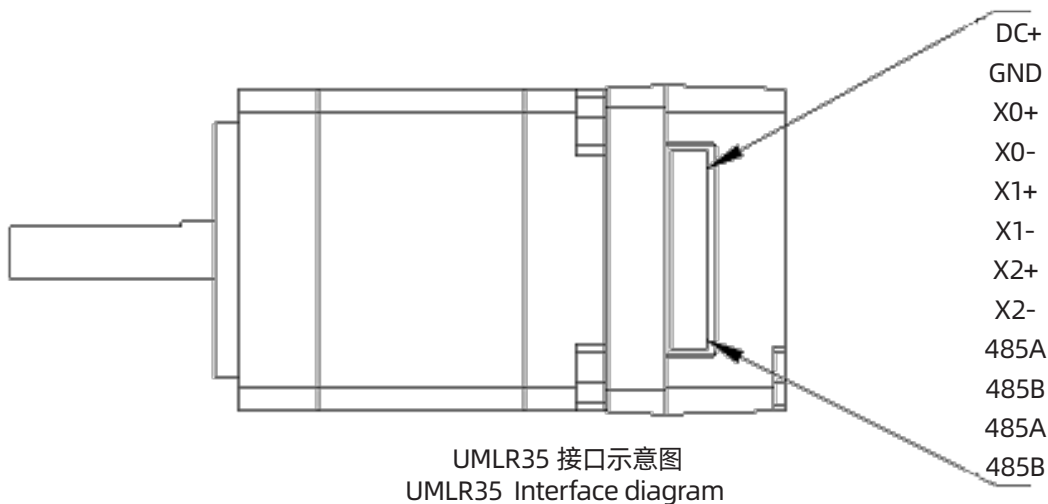

接口功能总体描述 / General Description of Interface Function

名称 Item	说明 Description
GND	供电电源负极 Negative pole of power supply
DC+	供电电源正极, 范围: DC12~40V Positive pole of power supply, range: DC12~40V
X0+ X0-	DC 5V~24V 供电, 接外部输入信号, 可支持差分输入 DC 5V~24V power supply, connect external input signal, support differential input
X1+ X1-	DC 5V~24V 供电, 接外部输入信号, 可支持差分输入 DC 5V~24V power supply, connect external input signal, support differential input
X2+ X2-	DC 5V~24V 供电, 接外部输入信号, 可支持差分输入 DC 5V~24V power supply, connect external input signal, support differential input
485A 485B	485 通讯接口 A B 端 485 communication interface A and B
485A 485B	连接至下一驱动的 485 通讯接口 A B 端 Connect to the 485 communication interface A B end of the next drive

指示灯 / Indicator Light

UMLR35 一体式 485 总线型闭环步进驱动器的指示灯为内缩式贴片 LED, 其基本功能如下表所示。

The indicator light of UMLR35 integrated 485 bus closed-loop stepper driver is a retracted SMD LED, and its basic functions are shown in the following table.

名称 Item	功能 Function	说明 Description
绿色 LED Green LED 红色 LED Red LED	电源、报警指示灯、保存参数功能指示、恢复出厂设置功能指示、拨码状态切换指示; Power supply, alarm indicator light, save parameter function Can indicate, restore factory settings function instructions, Dial status switching indication;	通电正常时绿灯常亮, 红灯熄灭。保存参数、恢复出厂设置、拨码状态发生切换、设备发生异常时, 红绿灯交替闪烁报警, 其闪烁规律查看第六章节; When the power is on normally, the green light is always on and the red light is off. When saving parameters, restoring factory settings, switching the dial status, or abnormal equipment occurs, the red and green lights flash alternately to alarm. For the flashing pattern, please refer to Chapter 6

RS485 通讯接口 / RS485 Communication Interface

UMLR35 一体式 485 总线型闭环步进驱动器的通讯接口采用 JST1.25-12P 的直针插座，如下图所示。

其接口共有 12 个引脚，自上向下对应引脚 1~12，其中引脚 9、10、11、12 用于 RS485 的半双工通讯，引脚 9、10 为一组，接 485 通讯的 A、B 端，引脚 11、12 为一组，驱动内部分别与引脚 9、10 级联，可用于连接至下一驱动设备，其他引脚为其他功能，引脚定义如下表所示。

The communication interface of UMLR35 integrated 485 bus closed-loop stepper driver adopts JST1.25-12P straight pin socket, as shown in the figure below.

The interface has 12 pins in total, corresponding to pins 1 to 12 from top to bottom, of which pins 9, 10, 11, and 12 are used for half-duplex communication of RS485. Pins 9 and 10 are a group, connected to the A and B ends of 485 communication, and pins 11 and 12 are a group. They are cascaded with pins 9 and 10 inside the driver, respectively, and can be used to connect to the next driver device. Other pins have other functions. The pin definitions are shown in the following table.

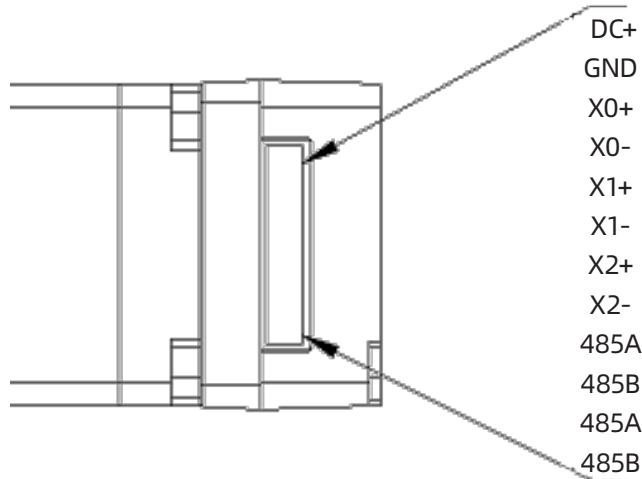

UMLR35 一体式 485 总线型闭环步进驱动器接口示意图
UMLR35 integrated 485 bus closed-loop stepper driver interface diagram

引脚 Pin	定义 Definition
X0+、X0-、X1+、X1-、X2+、X2-	输入 IO 口 Input IO port
485A 485B	485 通讯接口 A B 端 485 communication interface A and B
485A 485B	连接至下一驱动的 485 通讯接口 A B 端 Connect to the 485 communication interface A B end of the next drive

尺寸图 / Dimensions

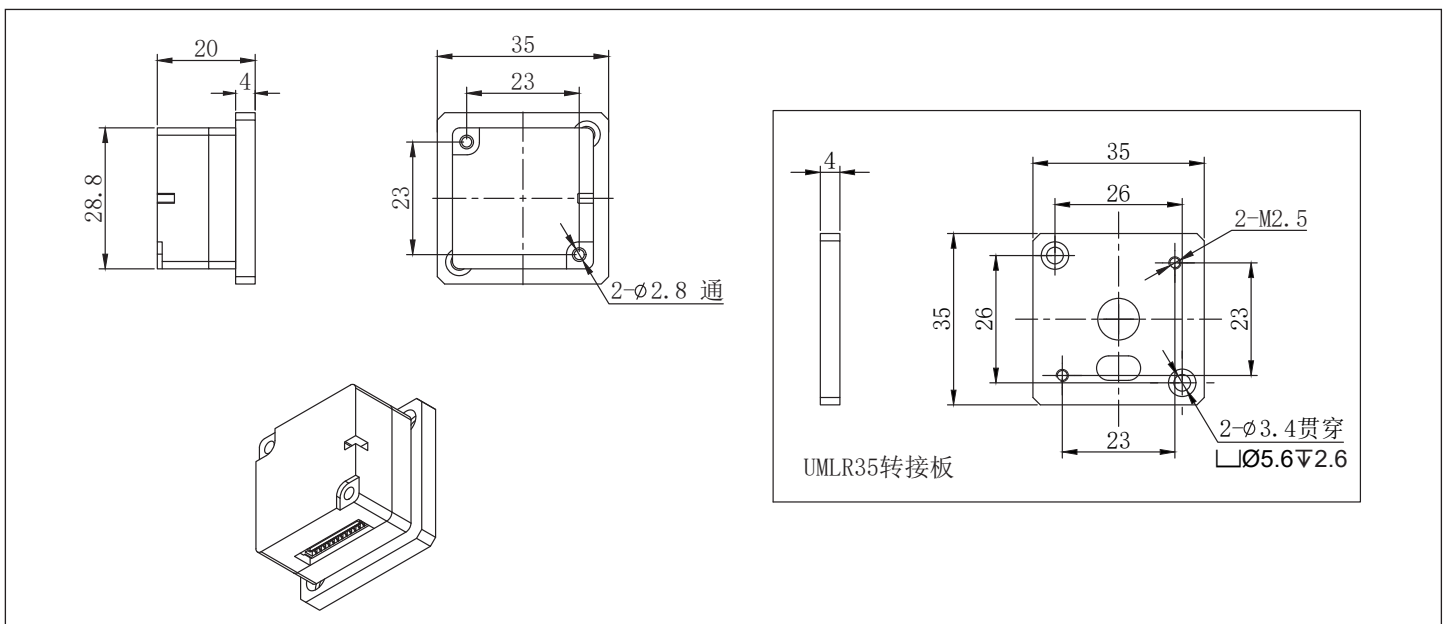

35 旋转一体式步进电机 (闭环 RS485)

35 Stepper Motor with Integrated Driver (Closed Loop RS485)



性能规格书 / Technical Data

Model No.	保持转矩 Holding Torque (mN.m)	额定电流 Rated Current (A)	相电阻 Resistance (Ω)	额定电压 Rated Voltage (V)	转动惯量 Rotor Inertia (g-cm ²)	机身长度 (L) Length(L) (mm)
28HS2401	200	1.0	4.5	4.5	25	28
28HS4401	140	1.0	2.7	2.7	18	32.5
28HS7401	250	1.0	4.5	4.5	35	38.5

尺寸图 / Dimensions

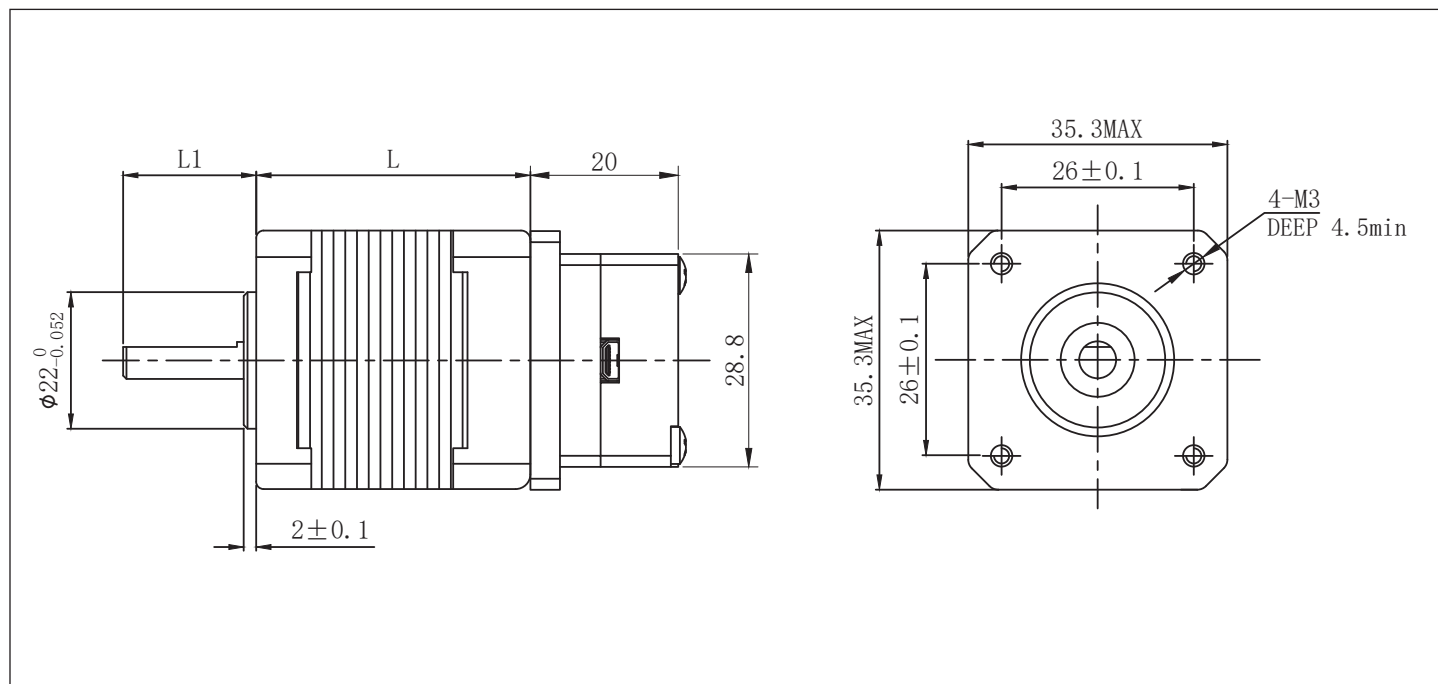

42 一体式步进驱动器 (闭环 RS485)

42 Integrated Stepper Motor Driver (Closed Loop RS485)

UMLR42

产品概述 / Product Description

UMLR42 一体式 485 总线型闭环步进驱动器是最新推出的带串口调试功能的数字式混合步进伺服驱动器，集成了 MODBUS-RTU 标准协议规范，供电、IO 输入输出以及通讯接口采用 PH2.0-10P 针座，用户可通过上位机调试软件设置细分、电流、速度、工作模式等多种参数，极大地丰富了产品的实用功能，能够满足大多数场合的应用需要。

UMLR42 integrated 485 bus closed-loop stepper driver is the latest digital hybrid stepper motor driver with serial port debugging function. It integrates MODBUS-RTU standard protocol specifications. The power supply interface, IO input and output ports and communication interface use PH2.0-10P pin sockets. Users can set various parameters such as subdivision, current, speed, working mode, etc. through the controller software, which greatly enriches the practical functions of the product and can meet the application needs of most occasions.

产品特点 / Feature

- 新一代 32 位 DSP 技术，平稳性佳、兼容性强、性价比高
New generation of 32-bit DSP technology, with good stability, strong compatibility and high cost performance
- 支持速度模式、位置模式、多段位置模式 (保留) 及回原点模式
Support speed mode, position mode, multi-segment position mode (reserved) and return to origin mode
- 电流、锁机电流、细分、PI 等参数都可通过主站设置及查询
Current, lock current, subdivision, PI and other parameters can be set and queried through the master station.
- 采用 RS485 总线，带隔离，支持标准 MODBUS-RTU 协议
Use RS485 bus, with isolation, support standard MODBUS-RTU protocol
- 拨码 SW1-4 设置驱动器通讯地址，可支持 15 个设备，更多可通过主站设置
Dial code SW1-4 sets the driver communication address, which can support 15 devices, and more can be set through the master station
- 1 路光电隔离可编程输入接口，接收外部控制信号，实现驱动器使能，启停，限位等功能
1 optoelectronic isolation programmable input interface, receives external control signals, and meets driver enable, start and stop, limit and other functions
- 1 路光电隔离可编程输出接口，输出驱动器状态及控制信号，如报警、到位、回原点完成等功能
1 optoelectronic isolation programmable output interface, outputs driver status and control signals, such as alarm, in place, return to origin completion and other functions
- 内置微细分，低速平稳性极佳
Built-in micro-segmentation, good work for low-speed and stability
- 具有过流 (保留)、过压、欠压、缺相等报警保护功能
With overcurrent (reserved), overvoltage, undervoltage, lack of phase and other alarm protection functions
- 纯正弦电流矢量控制有效降低电机发热
Pure sinusoidal current vector control effectively reduces motor heating
- 直流供电，输入电压范围：DC12V~40V
DC power supply, input voltage range: DC12V~40V



应用领域 / Application

适合各种中小型自动化设备和仪器，例如：雕刻机、打标机、切割机、绘图仪、数控机床、自动装配设备等。在用户期望小噪声、高速度的设备应用中应用效果特佳。

Suitable for various small and medium-sized automation equipment and instruments, such as: engraving machine, marking machine, cutting machine, plotter, CNC machine tool, automatic assembly equipment, etc. The application effect is particularly good in the application of equipment where users expect low noise and high speed.

电气指标 / Specifications

说明 Description	UMLR42			
	最小值 Minimum	典型值 Normally	最大值 Max	单位 unit
输出电流 Output Current	0	-	2000	mA
输入电源电压 Input Voltage	12	24	40	VDC
控制信号输入电流 Input Signal Current	7	10	16	mA
绝缘电阻 Insulation Resistance	50	-	-	MΩ

使用环境及参数 / Working Environment

冷却方式 Cooling		自然冷却、风扇散热 Natural cooling, air cooling
使用环境 Working Environment	场合 Environment	不能放在其他发热的设备旁, 要避免粉尘、油雾、腐蚀性气体, 湿度太大及强振动场所, 禁止有可燃气体和导电灰尘 Do not work to other heating equipment. Avoid dust, oil mist, corrosive gases, places with excessive humidity and strong vibrations. No combustible gases are allowed. body and conductive dust
	温度 Temperature	-25-55°C
	湿度 Humidity	40-90%RH
	振动 Vibration	10~55Hz/0.15mm
保存温度 Storage Temperature		-25°C ~65°C

产品接口总体描述 / General Description of Product Interface

UMLR42 一体式 485 总线型闭环步进驱动器的供电、IO 输入输出以及通讯接口采用 PH2.0-10P 的直针插座, 其共有 10 个引脚, 如下图所示

The power supply, IO input and output port and communication interface of UMLR42 integrated 485 bus closed-loop stepper driver adopt PH2.0-10P straight pin socket, which has a total of 10 pins, as shown in the figure below.

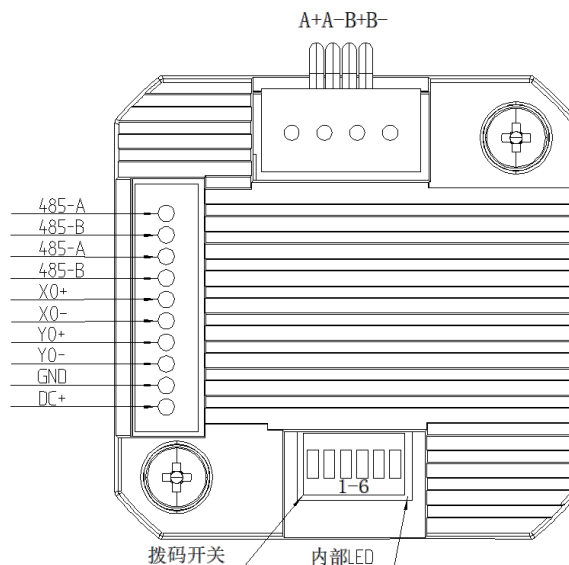

UMLR42 接口示意图
UMLR42 Interface diagram

引脚 Pin	名称 Item	说明 Description
1	DC+	供电电源正极, 范围: DC12~40V Positive pole of power supply, range: DC12~40V
2	GND	供电电源负极 Negative pole of power supply
3	Y0-	光电隔离可编程输出接口 (最大驱动电流 50mA) Opto-isolated programmable output interface (maximum drive current 50mA)
4	Y0+	
5	X0-	DC 5V~24V 供电, 接外部输入信号负端, 可支持差分输入 DC 5V~24V power supply, connected to the negative end of the external input signal, can support differential input
6	X0+	DC 5V~24V 供电, 接外部输入信号正端, 可支持差分输入 DC 5V~24V power supply, connected to the positive end of the external input signal, can support differential input
7	485-B	485 通讯接口 B 端 485 communication interface B
8	485-A	485 通讯接口 A 端 485 communication interface A
9	485-B	485 通讯接口 B 端 485 communication interface B
10	485-A	485 通讯接口 A 端 485 communication interface A

拨码开关 /DIP Switch

名称 Item	功能 Function	说明 Description
拨码开关 SW1-SW6 DIP switch SW1-SW6	设置地址、波特率、终端电阻 选择 Set address, baud rate, terminal resistance selection	SW1-SW4: 驱动器地址设置 SW1-SW4: Driver address setting
		SW5: 波特率设置 SW5: Baud rate setting
		SW6: 120Ω 终端电阻有效位 SW6: 120Ω terminal resistance valid bit

驱动器地址设置 /Driver Address Setting

上位机使用 RS485 总线通讯, 使用拨码最多可以控制 15 台 485 驱动器, 驱动器通讯地址通过 SW1-SW4 拨码设置, off 代表 0, on 代表 1, 每一位拨码对应一个十六进制数据, 地址范围为 1-15, 如表所示。当驱动器地址设置大于 15 时, 需要使用主机发送更改地址指令进行设置, 但在设置前需将 SW1-SW4 拨码全设置为 off 状态, 设置完成并保存后, 需重新上电生效。

The controller with RS485 bus communication, can control up to 15 drivers by the dial switch. The driver communication address is set by the SW1-SW4 dial switch. Off represents 0, on represents 1, and each dial switch corresponds to a hexadecimal data. The address range is 1-15, as shown in the table. When the driver address is set to be greater than 15, the host needs to send a change address command to set it, but before setting, all SW1-SW4 dial switches need to be set to off. After the setting is completed and saved, it needs to be powered on again to take effect.

注意: 需确保每台驱动器通讯地址的唯一性, 否则会引起通讯冲突!

Ensure that the communication address of each drive is unique, otherwise communication conflicts will occur!

SW1	SW2	SW3	SW4	= 地址 (ID)
on=1 off=0 x 1	on=1 off=0 x 2	on=1 off=0 x 4	on=1 off=0 x 8	
off	off	off	off	1(可自定义) Customizable
on	off	off	off	1
off	on	off	off	2
on	on	off	off	3
off	off	on	off	4
on	off	on	off	5
off	on	on	off	6
on	on	on	off	7
off	off	off	on	8
on	off	off	on	9
off	on	off	on	10
on	on	off	on	11
off	off	on	on	12
on	off	on	on	13
off	on	on	on	14
on	on	on	on	15

通讯波特率设置 / Communication Baud Rate Setting

通讯波特率可通过 SW5 设置。若表中通讯波特率不能满足使用要求时，可以通过上位机自定义通讯波特率，前提是需将 SW5 拨至 off 状态，详见寄存器 0x0015 的描述。

Communication baud rate can be set through SW5. If the communication baud rate in the table cannot meet the use requirements, the communication baud rate can be customized through the host computer, provided that SW5 is turned off. For details, see the description of register 0x0015.

SW5	波特率 Baud rate
off	9600 (可自定义) Customizable
on	115200

终端电阻设置 / Terminal Resistance Setting

通用户可通过拨码 SW6 选择通讯末端是否并入 120Ω 终端电阻，根据使用场合确定。

The user can select whether to incorporate a 120Ω terminal resistor into the communication terminal through the dial code SW6, which is determined according to the use occasion.

SW6	120Ω 终端电阻 120Ω terminal resistor
off	无效 Invalid
on	有效 Valid

电流大小设置 /Current Setting

UMLR42 一体式 485 总线型闭环步进驱动器，开环模式下默认电流。其不能通过拨码设置电流大小，若用户想自行调整电流的大小，可通过上位机软件设置。

UMLR42 integrated 485 bus closed-loop stepper driver, the default current in open-loop mode. The current cannot be set by switch. If the user wants to adjust the current by himself, it can be set through the host computer software.

电流设置 (A) Current Setting	闭环 Closed loop	
	Imin(A)	Imax(A)
默认 Default	0.3	1.5

指示灯 /Indicator Light

UMLR42 一体式 485 总线型闭环步进驱动器的指示灯为内缩式贴片 LED，其基本功能如下表所示。

The indicator light of UMLR42 integrated 485 bus closed-loop stepper driver is a retracted SMD LED, and its basic functions are shown in the following table

名称 Item	功能 Function	说明 Description
绿色 LED Green LED 红色 LED Red LED	电源、报警指示灯、保存参数功能指示、恢复出厂设置功能指示、拨码状态切换指示； Power supply, alarm indicator light, save parameter function Can indicate, restore factory settings function instructions, Dial status switching indication;	通电正常时绿灯常亮,红灯熄灭。保存参数、恢复出厂设置、拨码状态发生切换、设备发生异常时,红绿灯交替闪烁报警,其闪烁规律查看第六章节; When the power is on normally, the green light is always on and the red light is off. When saving parameters, restoring factory settings, switching the dial status, or abnormal equipment occurs, the red and green lights flash alternately to alarm. For the flashing pattern, please refer to Chapter 6

RS485 通讯接口 /RS485 Communication Interface

UMLR42 一体式 485 总线型闭环步进驱动器的通讯接口采用 PH2.0-10P 的直针插座，如下图所示。

其接口共有 10 个引脚，从下至上对应引脚 1~10，其中引脚 7、8、9、10 用于 RS485 的半双工通讯，引脚 7、8 为一组，接 485 通讯的 B、A 端，引脚 9、10 为一组，驱动内部分别与引脚 7、8 级联，可用于连接至下一驱动设备，实际使用时建议采用链式方式一级一级在此接口处串接下去，引脚定义如下表所示。

The communication interface of UMLR42 integrated 485 bus closed-loop stepper driver adopts PH2.0-10P straight pin socket, as shown in the figure below.

The interface has 10 pins in total, corresponding to pins 1 to 10 from top to bottom, of which pins 7,8,9,10 are used for half-duplex communication of RS485. Pins 7 and 8 are a group, connected to the A and B ends of 485 communication, and pins 9 and 10 are a group. They are cascaded with pins 7 and 8 inside the driver, respectively, and can be used to connect to the next driver device. Other pins have other functions. The pin definitions are shown in the following table.

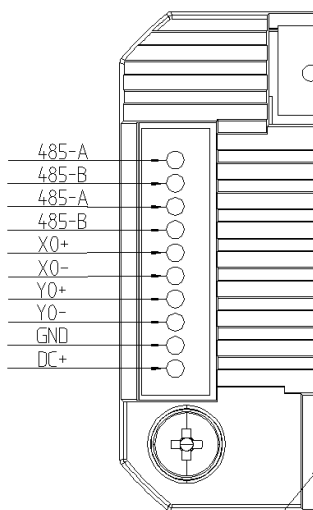

UMLR42 一体式 485 总线型闭环步进驱动器接口示意图
UMLR42 integrated 485 bus closed-loop stepper driver interface diagram

引脚 Pin	定义 Definition
DC+	供电电源正端 power supply positive terminal
GND	供电电源 GND 端 power supply GND terminal
X0+、X0-	输入 IO 口 Input IO port
Y0+、Y0-	输出 IO 口 Output IO port
485-B	RS485 通讯端口 B 端 485 communication interface B
485-A	RS485 通讯端口 A 端 485 communication interface A

尺寸图 / Dimensions

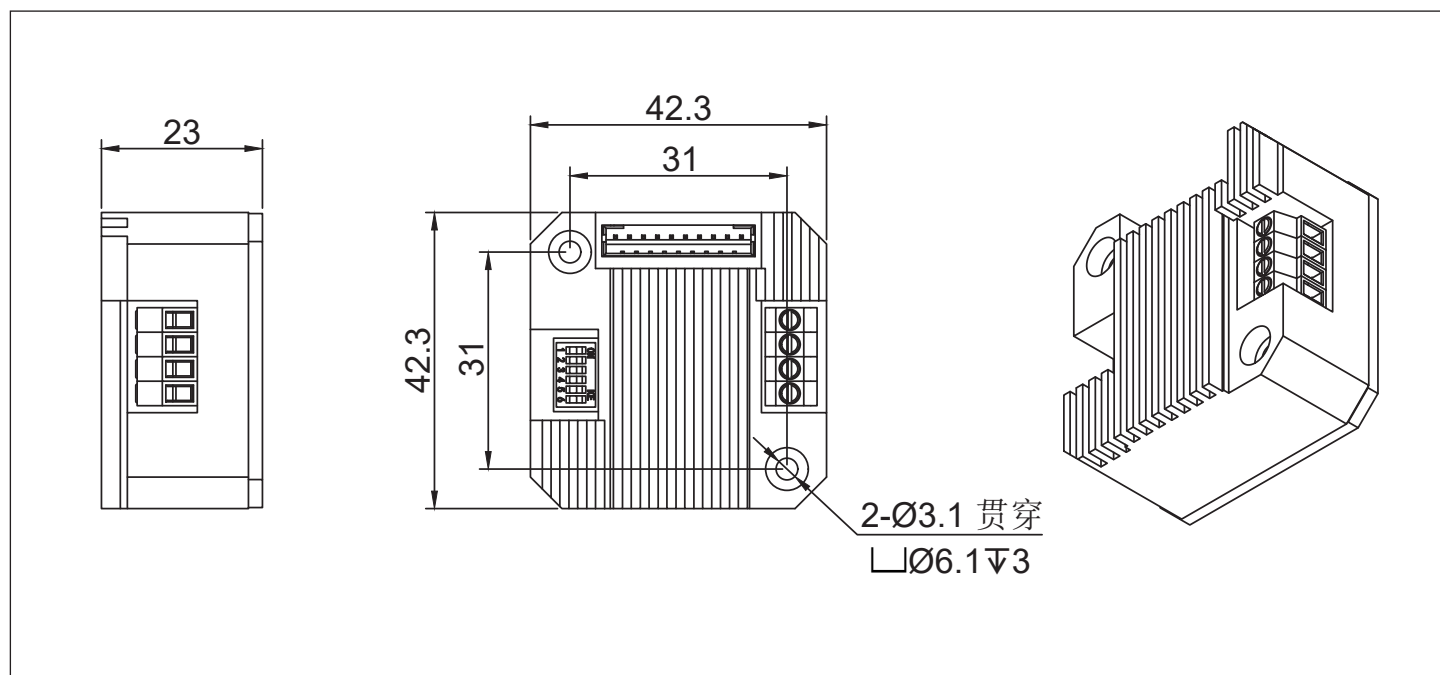

42 旋转一体式步进电机 (闭环 RS485)

42 Stepper Motor with Integrated Driver (Closed Loop RS485)



性能规格书 / Technical Data

Model No.	保持转矩 Holding Torque (mN.m)	额定电流 Rated Current (A)	相电阻 Resistance (Ω)	额定电压 Rated Voltage (V)	转动惯量 Rotor Inertia (g-cm ²)	机身长度 (L) Length(L) (mm)
42HSC1409	270	1.33	2.2	2.93	40	34
42HSC4409	380	1.5	1.65	3.3	40	40
42HSC6413	480	1.5	2.5	3.75	68	48
42HSC8402	600	1.5	2.0	3.0	100	60.5

尺寸图 / Dimensions

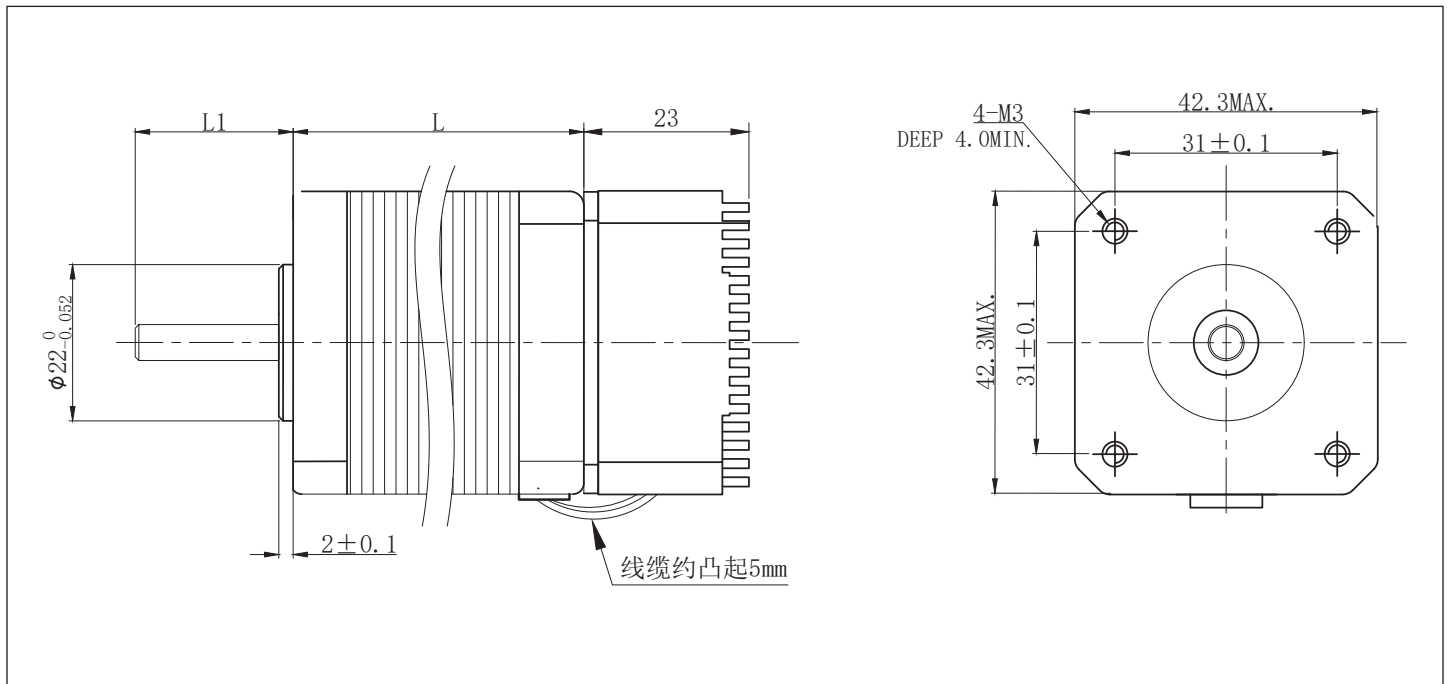

57 一体式步进驱动器 (闭环 RS485)

57 Integrated Stepper Motor Driver (Closed Loop RS485)

UMLR57

产品概述 / Product Description

UMLR57 一体式 485 总线型闭环步进驱动器是最新推出的带串口调试功能的数字式混合步进伺服驱动器，集成了 MODBUS-RTU 标准协议规范，供电接口采用 XH2.54-2P 针座，IO 输入输出以及通讯接口采用 PHB2.0-2x6P 针座，用户可通过上位机调试软件设置细分、电流、速度、工作模式等多种参数，极大地丰富了产品的实用功能，能够满足大多数场合的应用需要。

UMLR57 integrated 485 bus closed-loop stepper driver is the latest digital hybrid stepper driver with serial port debugging function. It integrates MODBUS-RTU standard protocol specifications. The power supply interface adopt XH2.54-2P straight pin socket, IO input and output ports and communication interface use PHB2.0-2x6P pin sockets. Users can set various parameters such as subdivision, current, speed, working mode, etc. through the controller software, which greatly enriches the practical functions of the product and can meet the application needs of most occasions.

产品特点 / Feature

- 新一代 32 位 DSP 技术，平稳性佳、兼容性强、性价比高
New generation of 32-bit DSP technology, with good stability, strong compatibility and high cost performance
- 支持速度模式、位置模式、多段位置 / 速度模式、JOG+、JOG- 及回原点模式
Support speed mode, position mode, multi-segment position/speed mode, JOG+, JOG- and return to origin mode.
- 电流、锁机电流、细分、PI 等参数都可通过主站设置及查询
Current, lock current, subdivision, PI and other parameters can be set and queried through the master station.
- 采用 RS485 总线，带隔离，支持标准 MODBUS-RTU 协议
Use RS485 bus, with isolation, support standard MODBUS-RTU protocol
- 拨码 SW1-4 设置驱动器通讯地址，可支持 15 个设备，更多可通过主站设置
Dial code SW1-4 sets the driver communication address, which can support 15 devices, and more can be set through the master station
- 3 路光电隔离可编程输入接口，接收外部控制信号，实现驱动器使能，启停，限位等功能
3 optoelectronic isolation programmable input interface, receives external control signals, and meets driver enable, start and stop, limit and other functions
- 1 路光电隔离可编程输出接口，输出驱动器状态及控制信号，如报警、到位、回原点完成等功能
1 optoelectronic isolation programmable output interface, outputs driver status and control signals, such as alarm, in place, return to origin completion and other functions
- 内置微细分，低速平稳性极佳
Built-in micro-segmentation, good work for low-speed and stability
- 具有过流 (保留)、过压、欠压、缺相等报警保护功能
With overcurrent (reserved), overvoltage, undervoltage, lack of phase and other alarm protection functions
- 纯正弦电流矢量控制有效降低电机发热
Pure sinusoidal current vector control effectively reduces motor heating
- 直流供电，输入电压范围：DC12V~50V
DC power supply, input voltage range: DC12V~50V



应用领域 / Application

适合各种中小型自动化设备和仪器，例如：雕刻机、打标机、切割机、绘图仪、数控机床、自动装配设备等。在用户期望小噪声、高速度的设备应用中应用效果特佳。

Suitable for various small and medium-sized automation equipment and instruments, such as: engraving machine, marking machine, cutting machine, plotter, CNC machine tool, automatic assembly equipment, etc. The application effect is particularly good in the application of equipment where users expect low noise and high speed.

电气指标 / Specifications

说明 Description	UMLR57			
	最小值 Minimum	典型值 Normally	最大值 Max	单位 unit
输出电流 Output Current	0	-	6000	mA
输入电源电压 Input Voltage	12	24	50	VDC
控制信号输入电流 Input Signal Current	7	10	16	mA
绝缘电阻 Insulation Resistance	50	-	-	MΩ

使用环境及参数 / Working Environment

冷却方式 Cooling		自然冷却、风扇散热 Natural cooling, air cooling
使用环境 Working Environment	场合 Environment	不能放在其他发热的设备旁, 要避免粉尘、油雾、腐蚀性气体, 湿度太大及强振动场所, 禁止有可燃气体和导电灰尘 Do not work to other heating equipment. Avoid dust, oil mist, corrosive gases, places with excessive humidity and strong vibrations. No combustible gases are allowed. body and conductive dust
	温度 Temperature	-25-55°C
	湿度 Humidity	40-90%RH
	振动 Vibration	10~55Hz/0.15mm
保存温度 Storage Temperature		-25°C ~65°C

产品接口总体描述 / General Description of Product Interface

UMLR57 一体式 485 总线型闭环步进驱动器的供电接口采用 XH2.54-2P 直针插座, IO 输入输出以及通讯接口采用 PHB2.0-2x6P 直针插座, 如下图所示

The power supply interface adopt XH2.54-2P straight pin socket, IO input and output port and communication interface of UMLR57 integrated 485 bus closed-loop stepper driver adopt PHB2.0-2x6P straight pin socket, as shown in the figure below.

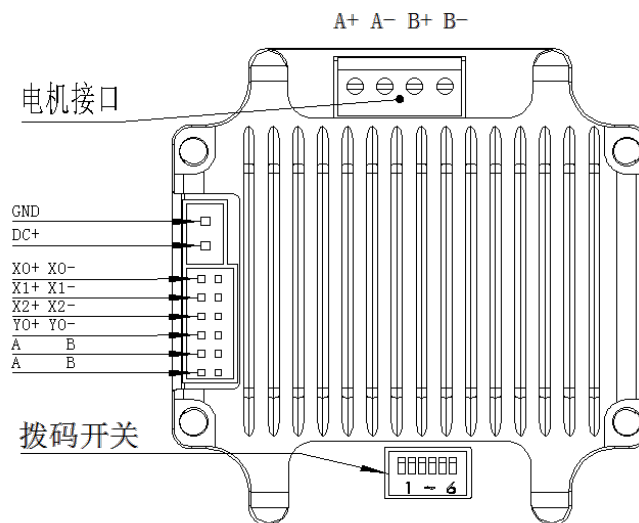

UMLR57 接口示意图
UMLR57 Interface diagram

名称 Item	说明 Description
GND	供电电源负极 Negative pole of power supply
DC+	供电电源正极, 范围: DC12~50V Positive pole of power supply, range: DC12~50V
X0+ X0-	DC 5V~24V 供电, 接外部输入信号负端, 可支持差分输入 DC 5V~24V power supply, connected to the negative end of the external input signal, can support differential input
X1+ X1-	DC 5V~24V 供电, 接外部输入信号正端, 可支持差分输入 DC 5V~24V power supply, connected to the positive end of the external input signal, can support differential input
X2+ X2-	DC 5V~24V 供电, 接外部输入信号正端, 可支持差分输入 DC 5V~24V power supply, connected to the positive end of the external input signal, can support differential input
Y0+ Y0-	光电隔离可编程输出接口 (最大驱动电流 50mA) Opto-isolated programmable output interface (maximum drive current 50mA)
A B	485 通讯接口 A B 端 485 communication interface A and B
A B	连接至下一驱动的 485 通讯接口 A B 端 Connect to the 485 communication interface A B end of the next drive

拨码开关 / DIP Switch

名称 Item	功能 Function	说明 Description
拨码开关 SW1-SW6 DIP switch SW1-SW6	设置地址、波特率、终端电阻 选择 Set address, baud rate, terminal resistance selection	SW1-SW4: 驱动器地址设置 SW1-SW4: Driver address setting
		SW5: 波特率设置 SW5: Baud rate setting
		SW6: 120Ω 终端电阻有效位 SW6: 120Ω terminal resistance valid bit

驱动器地址设置 / Driver Address Setting

上位机使用 RS485 总线通讯, 使用拨码最多可以控制 15 台 485 驱动器, 驱动器通讯地址通过 SW1-SW4 拨码设置, off 代表 0, on 代表 1, 每一位拨码对应一个十六进制数据, 地址范围为 1-15, 如表所示。当驱动器地址设置大于 15 时, 需要使用主机发送更改地址指令进行设置, 但在设置前需将 SW1-SW4 拨码全设置为 off 状态, 设置完成并保存后, 需重新上电生效。

The controller with RS485 bus communication, can control up to 15 drivers by the dial switch. The driver communication address is set by the SW1-SW4 dial switch. Off represents 0, on represents 1, and each dial switch corresponds to a hexadecimal data. The address range is 1-15, as shown in the table. When the driver address is set to be greater than 15, the host needs to send a change address command to set it, but before setting, all SW1-SW4 dial switches need to be set to off. After the setting is completed and saved, it needs to be powered on again to take effect.

注意: 需确保每台驱动器通讯地址的唯一性, 否则会引起通讯冲突!

Ensure that the communication address of each drive is unique, otherwise communication conflicts will occur.

SW1	SW2	SW3	SW4	= 地址 (ID)
on=1 off=0 x 1	on=1 off=0 x 2	on=1 off=0 x 4	on=1 off=0 x 8	
off	off	off	off	1(可自定义) Customizable
on	off	off	off	1
off	on	off	off	2
on	on	off	off	3
off	off	on	off	4
on	off	on	off	5
off	on	on	off	6
on	on	on	off	7
off	off	off	on	8
on	off	off	on	9
off	on	off	on	10
on	on	off	on	11
off	off	on	on	12
on	off	on	on	13
off	on	on	on	14
on	on	on	on	15

通讯波特率设置 / Communication Baud Rate Setting

通讯波特率可通过 SW5 设置。若表中通讯波特率不能满足使用要求时，可以通过上位机自定义通讯波特率，前提是需将 SW5 拨至 off 状态，详见寄存器 0x0015 的描述。

Communication baud rate can be set through SW5. If the communication baud rate in the table cannot meet the use requirements, the communication baud rate can be customized through the host computer, provided that SW5 is turned off. For details, see the description of register 0x0015.

SW5	波特率 Baud rate
off	9600 (可自定义) Customizable
on	115200

终端电阻设置 / Terminal Resistance Setting

通用用户可通过拨码 SW6 选择通讯末端是否并入 120Ω 终端电阻，根据使用场合确定。

The user can select whether to incorporate a 120Ω terminal resistor into the communication terminal through the dial code SW6, which is determined according to the use occasion.

SW6	120Ω 终端电阻 120Ω terminal resistor
off	无效 Invalid
on	有效 Valid

电流大小设置 /Current Setting

UMLR57 一体式 485 总线型闭环步进驱动器，默认电流如下表所示。其不能通过拨码设置电流大小，若用户想自行调整电流的大小，可通过上位机软件设置。

UMLR57 integrated 485 bus closed-loop stepper driver, the default current is shown in the following table. The current cannot be set by switches. If the user wants to adjust the current by himself, it can be set by the host computer software.

电流设置 (A) Current Setting	闭环 Closed loop	
	Imin(A)	Imax(A)
默认 Default	1.0	3.5

指示灯 /Indicator Light

UMLR57 一体式 485 总线型闭环步进驱动器的指示灯为内缩式贴片 LED，其基本功能如下表所示。

The indicator light of UMLR57 integrated 485 bus closed-loop stepper driver is a retracted SMD LED, and its basic functions are shown in the following table.

名称 Item	功能 Function	说明 Description
绿色 LED Green LED 红色 LED Red LED	电源、报警指示灯、保存参数功能指示、恢复出厂设置功能指示、拨码状态切换指示； Power supply, alarm indicator light, save parameter function Can indicate, restore factory settings function instructions, Dial status switching indication;	通电正常时绿灯常亮,红灯熄灭。保存参数、恢复出厂设置、拨码状态发生切换、设备发生异常时,红绿灯交替闪烁报警,其闪烁规律查看第六章; When the power is on normally, the green light is always on and the red light is off. When saving parameters, restoring factory settings, switching the dial status, or abnormal equipment occurs, the red and green lights flash alternately to alarm. For the flashing pattern, please refer to Chapter 6

RS485 通讯接口 /RS485 Communication Interface

UMLR57 一体式 485 总线型闭环步进驱动器的通讯接口采用 PH2.0*6P 的直针插座，如下图所示。

其接口共有 12 个引脚，从下至上对应引脚 1~12，其中引脚 9、10、11、12 用于 RS485 的半双工通讯，引脚 9、10 为一组，接 485 通讯的 A、B 端，引脚 11、12 为一组，驱动内部分别与引脚 9、10 级联，可用于连接至下一驱动设备，其他引脚为其他功能，引脚定义如下表所示。

The communication interface of UMLR57 integrated 485 bus closed-loop stepper driver adopts PH2.0*6P straight pin socket, as shown in the figure below.

The interface has 12 pins in total, corresponding to pins 1 to 12 from top to bottom, of which pins 9, 10, 11, and 12 are used for half-duplex communication of RS485. Pins 9 and 10 are a group, connected to the A and B ends of 485 communication, and pins 11 and 12 are a group. They are cascaded with pins 9 and 10 inside the driver, respectively, and can be used to connect to the next driver device. Other pins have other functions. The pin definitions are shown in the following table.

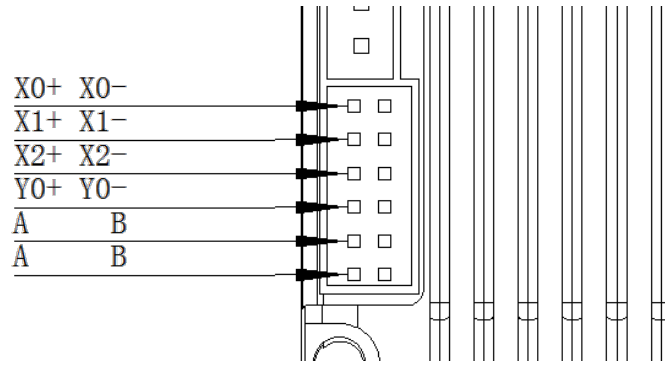

UMLR57 一体式 485 总线型闭环步进驱动器接口示意图
 UMLR57 integrated 485 bus closed-loop stepper driver interface diagram

引脚 Pin	定义 Definition
X0+, X0-, X1+, X1-, X2+, X2-, X0+	输入 IO 口 Input IO port
Y0+, Y0-	输出 IO 口 Output IO port
A B	485 通讯接口 A B 端 485 communication interface A and B
A B	连接至下一驱动的 485 通讯接口 A B 端 Connect to the 485 communication interface A B end of the next drive

尺寸图 / Dimensions

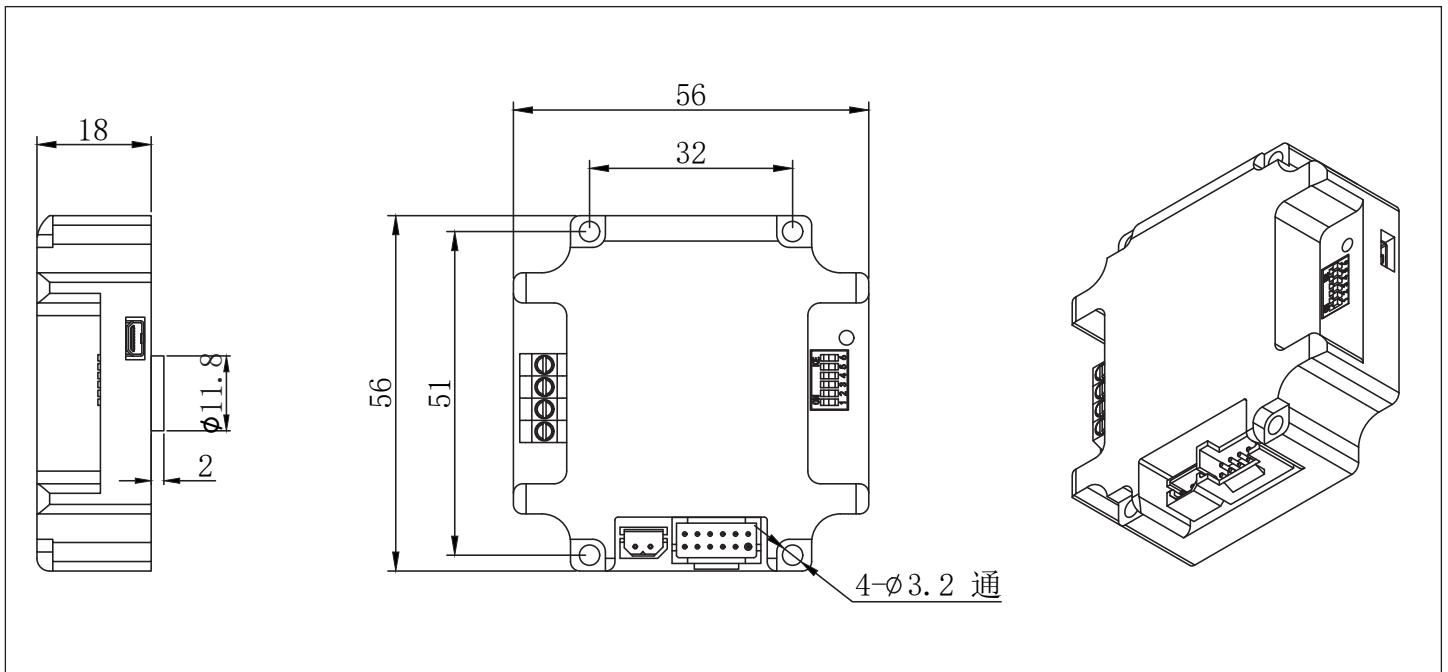

57 旋转一体式步进电机 (闭环 RS485)

57 Stepper Motor with Integrated Driver (Closed Loop RS485)



性能规格书 / Technical Data

Model No.	保持转矩 Holding Torque (mN.m)	额定电流 Rated Current (A)	相电阻 Resistance (Ω)	额定电压 Rated Voltage (V)	转动惯量 Rotor Inertia (g-cm ²)	机身长度 (L) Length(L) (mm)
57HS5417	950	2	0.85	1.7	200	55
57HS7407	1900	3	0.7	2.1	230	76

尺寸图 / Dimensions

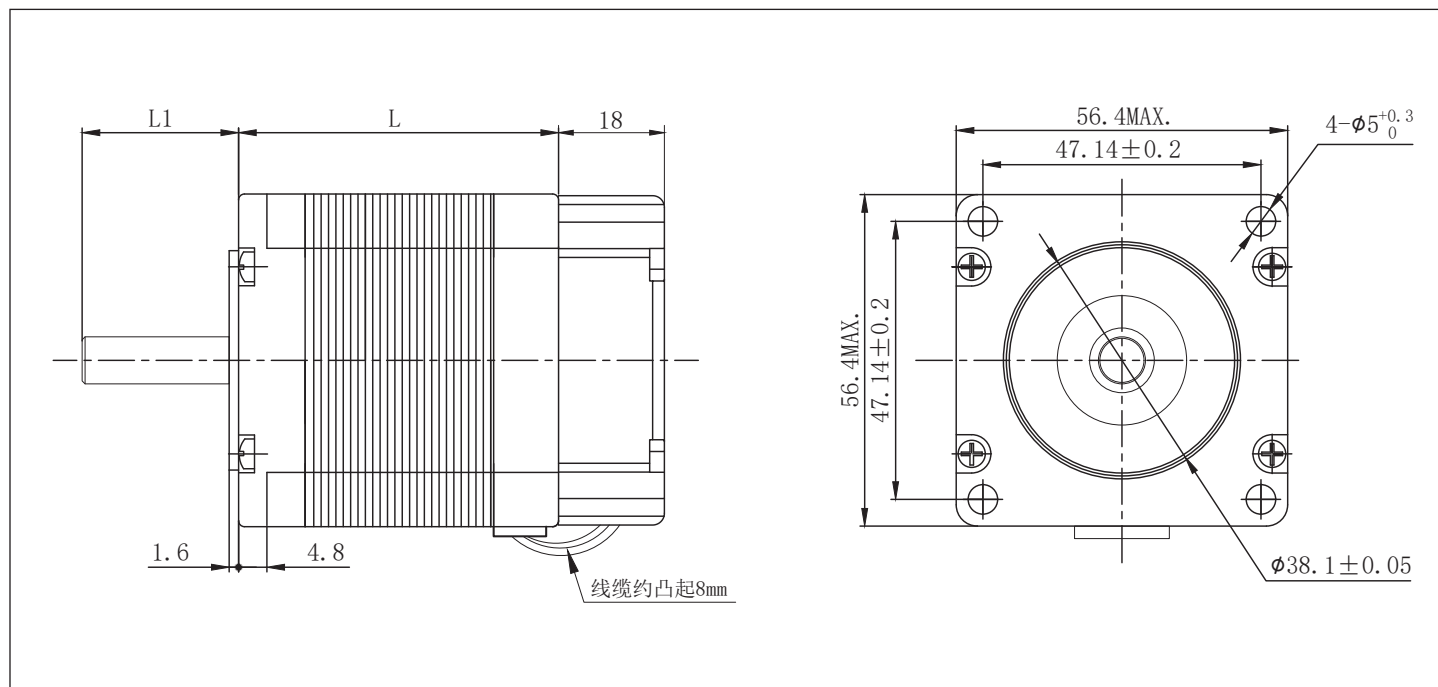

专
心 · 专
业 · 专
注



 微信搜一搜

 umot优摩特



+86 2386132606



www.umotmotor.cn



info@umottech.com



重庆市九龙坡区火炬大道101号2110号