

# 一体式蜗轮蜗杆 减速步进电机(闭环脉冲型)

28/35/42/57系列

Worm Geared Stepper Motor with Integrated Driver (Closed Loop Pulse Control)

选型手册Catalog



# CONTENTS

## 目录

<b>28 一体式步进驱动器 ( 闭环脉冲型 )</b> .....	<b>01</b>
28 Integrated Stepper Motor Driver (Closed Loop Pulse Control)	
<b>28 传动蜗轮蜗杆减速一体式步进电机 ( 闭环脉冲型 )</b> .....	<b>06</b>
28 Worm Geared Stepper Motor with Integrated Driver(Backlash $\leq 1.5^\circ$ ) (Closed Loop Pulse Control)	
<b>35 一体式步进驱动器 ( 闭环脉冲型 )</b> .....	<b>08</b>
35 Integrated Stepper Motor Driver (Closed Loop Pulse Control)	
<b>35 传动蜗轮蜗杆减速一体式步进电机 ( 闭环脉冲型 )</b> .....	<b>13</b>
35 Worm Geared Stepper Motor with Integrated Driver(Backlash $\leq 1.5^\circ$ )(Closed Loop Pulse Control)	
<b>42 一体式步进驱动器 ( 闭环脉冲型 )</b> .....	<b>15</b>
42 Integrated Stepper Motor Driver (Closed Loop Pulse Control)	
<b>42 传动蜗轮蜗杆减速一体式步进电机 ( 闭环脉冲型 )</b> .....	<b>19</b>
42 Worm Geared Stepper Motor with Integrated Driver(Backlash $\leq 1.5^\circ$ )(Closed Loop Pulse Control)	
<b>42 精密方形蜗轮蜗杆减速一体式步进电机 ( 闭环脉冲型 )</b> .....	<b>21</b>
42 Square Flange Worm Geared Stepper Motor with Integrated Driver(Backlash $\leq 15$ arcmin)(Closed Loop Pulse Control)	
<b>57 一体式步进驱动器 ( 闭环脉冲型 )</b> .....	<b>23</b>
57 Integrated Stepper Motor Driver (Closed Loop Pulse Control)	
<b>57 精密蜗轮蜗杆减速一体式步进电机 ( 闭环脉冲型 )</b> .....	<b>27</b>
57 Worm Geared Stepper Motor with Integrated Driver(Backlash $\leq 15$ arcmin)(Closed Loop Pulse Control)	

# 28 一体式步进驱动器 (闭环脉冲型)

28 Integrated Stepper Motor Driver (Closed Loop Pulse Control)

## UMLP28

### 产品概述 / Product Description

UMLP28 一体式脉冲型闭环步进驱动器是重庆优摩特科技有限公司最新推出的一款新型电机驱动一体化电机驱动器，采用最新专用电机控制数字信号处理器，提升电机的综合性能、降低电机的发热程度和减小电机的振动，采用电机和驱动器一体式设计，安装更加紧凑，减少外界干扰。

UMLP28 带串口调试功能，通讯采用 MINI USB 接口，用户可通过 PC 端上位机调试软件设置细分、电流、工作模式等多种参数，极大地丰富了产品的实用功能，能够满足绝大多数场合的应用。

UMLP28 integrated closed loop pulse stepper motor driver is new designed for open-loop stepper motor by UMot. It adopts the latest dedicated motor control. It uses a digital signal processor to improve the performance of the motor, reduce the heat and vibration of the motor. It adopts an integrated design of the motor and driver to install more compact.

UMLP28 has serial port debugging function, and the communication adopts MINI USB interface. Users can set various parameters such as subdivision, current, working mode, etc. through PC host debugging software, which greatly enriches the practical functions of the product and can meet various application.

### 产品特点 / Feature

- 电机和驱动一体化，节省接线人工  
No need to wire stepper motor with driver
- 体积小，便于安装  
Small size, easy install
- 新一代 32 位 DSP 技术，平稳性佳、兼容性强、性价比高  
New generation of 32-bit DSP technology, with good stability, strong compatibility and high cost performance
- 光隔离差分信号输入  
Optically isolated differential signal input
- 内置微细分，低速平稳性极佳  
Micro segmentation setting inside, stable work at low speed
- 脉冲响应频率最高可达 200KHz (更高可改)  
Impulse response frequency max to 200KHz  
(The max one can be changed)
- 细分设定范围 200-60000 (可通过上位机设置任意微细分)  
Subdivision setting range 200-60000  
(Any micro-segment can be set through the controller)
- 精密电流控制使电机发热大幅降低  
Precision current control significantly reduces motor heating
- 低振动低噪声  
Low vibration and low noise
- 具有过压、欠压、缺相等报警保护功能  
Overvoltage, undervoltage, phase loss protection
- 输入电压范围: DC12V~40V  
Input voltage range: DC12V-40V
- 默认有效电流 1.0A (也可通过上位机设置任意电流值)  
The default effective current is 1.0A  
(any current value can also be set through the controller)



### 应用领域 / Application

适合各种中小型自动化设备和仪器，例如：医疗设备、检测设备、打标机、绘图仪等。满足客户低噪声、低发热、布线方便，抗干扰性更强等要求。

Suitable for various small and medium-sized automation equipment and instruments, such as: medical equipment, testing equipment, marking machines, plotters, etc. Satisfy customers with low noise, low heat, convenient wiring and anti-interference performance stronger requirements.

## 电气指标 / Specifications

说明 Description	UMLP28			
	最小值 Minimum	典型值 Normally	最大值 Max	单位 unit
输入电源电压 Input Voltage	12	24	40	VDC
控制信号输入电流 Input signal current	7	10	16	mA
步进脉冲频率 Frequency	0	-	200	KHz
绝缘电阻 Insulation resistance	50			MΩ

## 使用环境及参数 / Working Environment

冷却方式 Cooling		自然冷却、风扇散热 Natural cooling, air cooling
使用环境 Working Environment	场合 Environment	不能放在其他发热的设备旁, 要避免粉尘、油雾、腐蚀性气体, 湿度太大及强振动场所, 禁止有可燃气体和导电灰尘 Do not work to other heating equipment. Avoid dust, oil mist, corrosive gases, places with excessive humidity and strong vibrations. No combustibile gases are allowed. body and conductive dust
	温度 Temperature	0-50°C
	湿度 Humidity	40-90%RH
	振动 Vibration	10~55Hz/0.15mm
保存温度 Storage Temperature		-20°C ~65°C

## 接口示意图 / Interface diagram

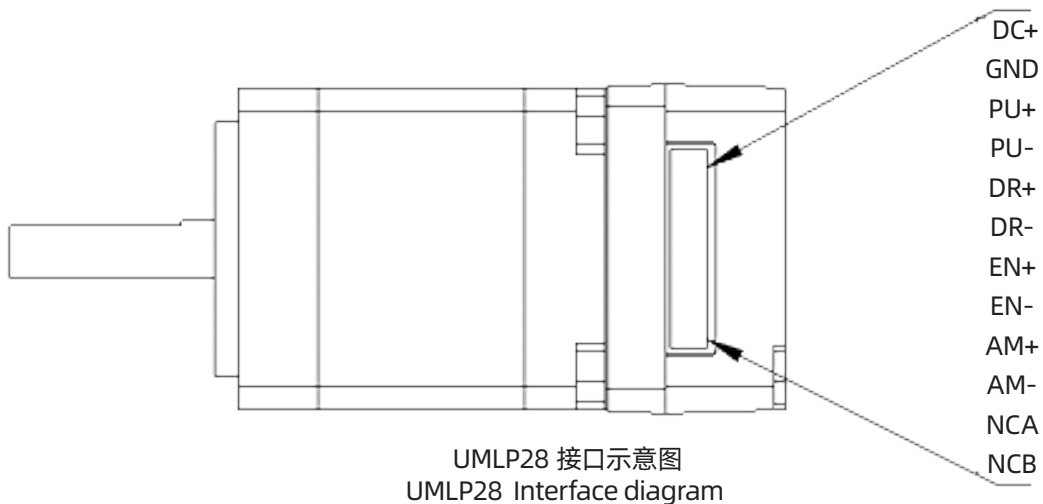

## 接口描述 /Interface description

UMLP28 一体式脉冲型闭环步进驱动器的电源接口与、信号控制接口和输出信号接口采用 JST1.25-12P 针座。接口具体定义看以下几个小节介绍。

The power interface, signal control interface and output signal interface of UMLP28 integrated pulse closed-loop stepper driver adopt JST1.25-12P pin socket. For the specific definition of the interface, please refer to the introduction of the following sections.

## 电源输入接口 /Power input interface

名称 Item		说明 Description	功能 Function
VDC	DC+	电源接口 Power connector	电源输入 DC12V~40V Power input DC12V-40V
	GND		

## 控制信号接口 /Control Signal Interface

名称 Item	功能 Function
PU+	脉冲控制信号: +5V-+24V 均可驱动, 上升沿有效, 每当脉冲由低变高时, 电机走一微步。为了可靠响应脉冲信号, 脉冲宽度应大于 2.5 $\mu$ s。
PU-	Pulse control signal: +5V-+24V can be driven, the rising edge is valid, every time the pulse changes from low to high, the motor takes a micro step. In order to respond reliably to pulse signals, the pulse width should be greater than 2.5 $\mu$ s.
DR+	方向控制信号: +5V-+24V 均可驱动, 高 / 低电平信号。为保证电机可靠换向, 方向信号应先于脉冲信号至少 50 $\mu$ s 建立。
DR-	Direction control signal: +5V-+24V can be driven, high/low level signal. In order to ensure reliable commutation of the motor, the direction signal should first It takes at least 50 $\mu$ s for the pulse signal to establish.
EN+	使能控制信号: +5V-+24V 均可驱动, 高 / 低电平信号。用于使能或禁止电机的运行。当 EN+ 接 +5V, EN- 接低电平时, 驱动器将切断电机各相的电流使电机处于自由状态, 此时步进脉冲不被响应。当不需用此功能时, 使能信号端悬空即可。另外, EN 端还可用于清除超差报警信号。
EN-	Enable control signal: +5V-+24V can be driven, high/low level signal. Used to enable or disable the operation of the motor. When EN+ When connected to +5V and EN- to low level, the driver will cut off the current of each phase of the motor to make the motor in a free state. At this time, the step pulse Not responded to. When this function is not needed, the enable signal terminal can be left floating. In addition, the EN terminal can also be used to clear the out-of-tolerance alarm signal.

## 输出信号接口 /Output signal interface

输出信号接口默认作为报警输出功能使用，当发生过压、欠压、缺相报警时，输出信号有效。此外，输出接口也可通过 PC 端上位机软件设置为到位输出、刹车控制输出功能使用，用户可根据实际使用情况做相应设置。

The output signal interface is used as the alarm output function by default. When overvoltage, undervoltage, and phase loss alarm occur, the output signal is valid. In addition, the output interface can also be set to in-position output and brake control output functions through the PC host software. Users can make corresponding settings according to actual usage.

名称 Item	功能 Function
AM+	报警信号输出: 过压、欠压、缺相报警发生时, 报警信号输出有效; Alarm signal output: When overvoltage, undervoltage, or phase loss alarm occurs, the alarm signal output is valid; 常开或常闭接法见 3.4 小节内描述; The normally open or normally closed connection method is described in Section 3.4;
AM-	最大驱动电流 50mA。 Maximum drive current 50mA。

名称 Item	功能 Function	说明 Description
绿色 LED Green LED  红色 LED Red LED	电源、报警指示灯、保存参数功能指示、恢复出厂设置功能指示、拨码状态切换指示; Power supply, alarm indicator light, save parameter function Can indicate, restore factory settings function instructions, Dial status switching indication;	通电正常时绿灯常亮, 红灯熄灭。保存参数、恢复出厂设置、拨码状态发生切换、设备发生异常时, 红绿灯交替闪烁报警, 其闪烁规律查看第五章; When the power is on normally, the green light is always on and the red light is off. When saving parameters, restoring factory settings, switching the dial status, or abnormal equipment occurs, the red and green lights flash alternately to alarm. For the flashing pattern, please refer to Chapter 5

## 输入控制信号接口电路 / Input control signal interface circuit

UMLP28 驱动器控制信号端采用差分式接口电路，可适用差分信号、单端共阴及共阳等接口，内置高速光电耦合器，在环境恶劣的场合，抗干扰能力强。接口电路示意图如图 3.2 所示。

The UMLP28 driver control signal end adopts a differential interface circuit, which can be used for differential signals, single-ended common cathode and common anode interfaces. It has a built-in high-speed photocoupler, which can be used in harsh environments.

Strong anti-interference ability. The schematic diagram of the interface circuit is shown in Figure 3.2.



图 3.2 输入接口电路  
Figure 3.2 Input interface circuit

## 尺寸图 / Dimensions

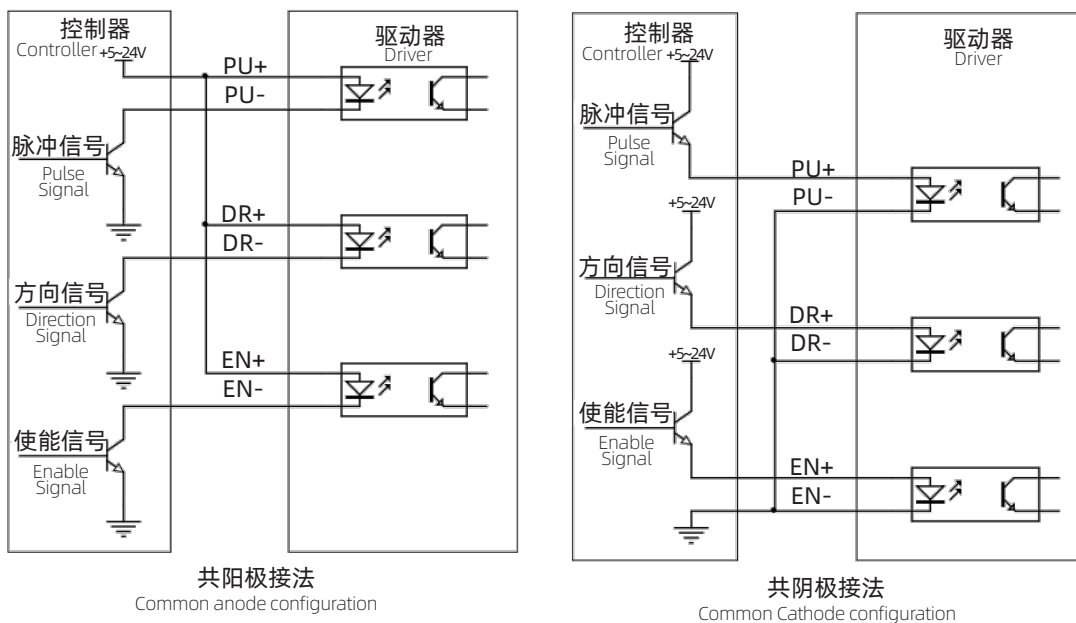
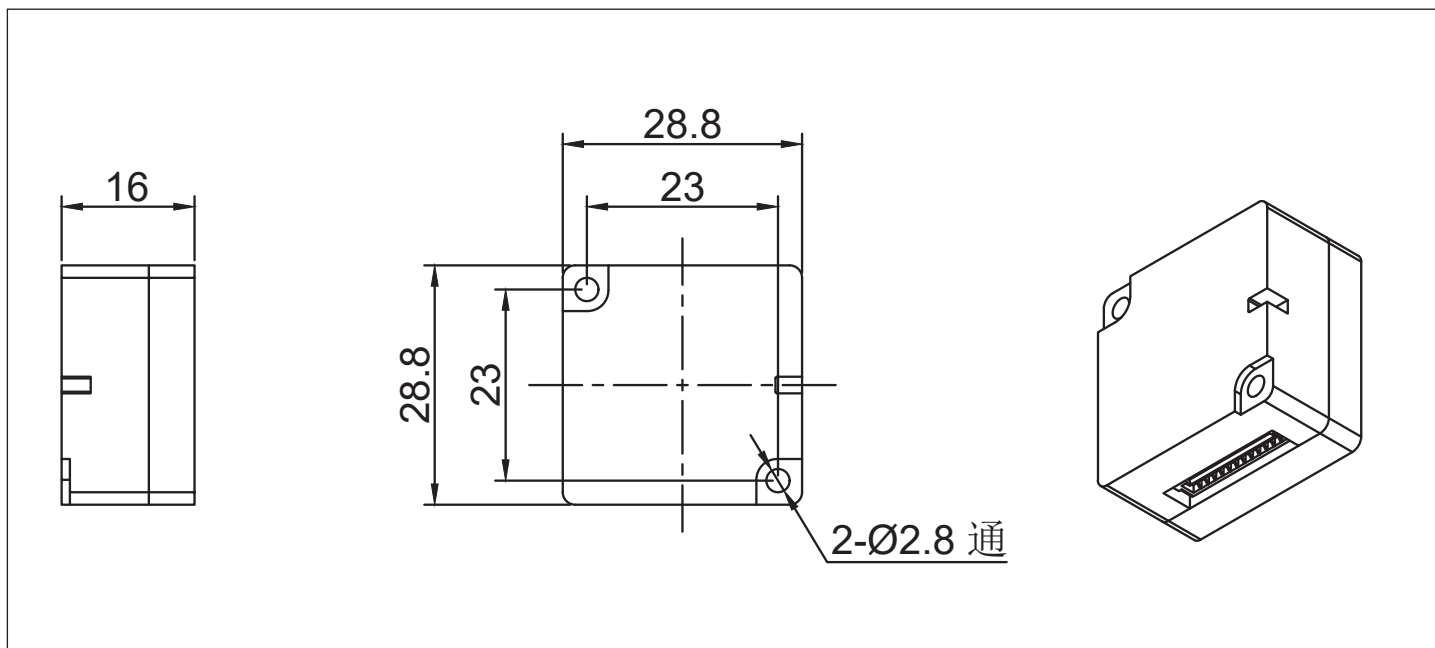

# 28 传动蜗轮蜗杆减速一体式步进电机 (闭环脉冲型)

28 Worm Geared Stepper Motor with Integrated Driver (Closed Loop Pulse Control)  
(Backlash  $\leq 1.5^\circ$ )

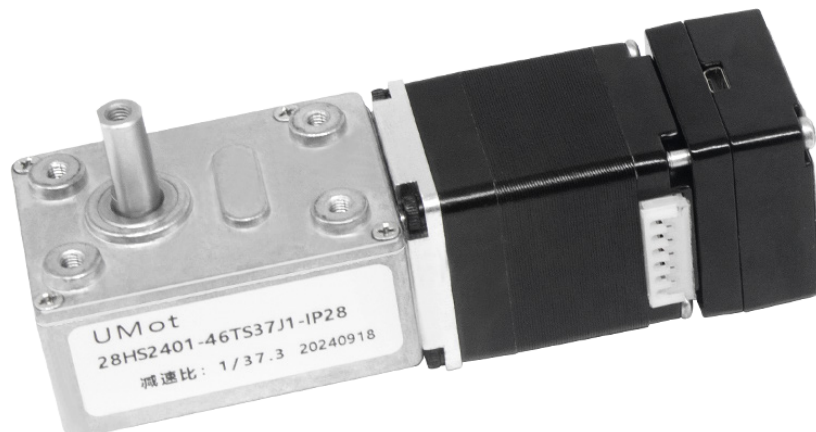

## 技术参数 / Technical Data

Model No.	额定电压 Rated Voltage (V)	每相电流 Current /Phase (A)	每相电阻 Resistance /Phase ( $\Omega$ )	每相电感 Inductance /Phase (mH)	保持转矩 Holding Torque (mN.m)	引出线数 #of Leads	转动惯量 Rotor Inertia (g-cm <sup>2</sup> )	重量 Weight (kg)	机身长度 (L) Length(L) (mm)	适配减速比 Max. Gear Ratio
28HS2401	3.88	0.67	5.8	4.2	70	4	15	0.13	32.5	$\leq 1: 970$
28HS5401	4.9	0.7	7	5	95	4	28	0.20	45	$\leq 1: 970$

## 减速电机性能参数 (28HS2401) / Geared Stepper Motor Specifications

减速比 Reduction Ratio	37.3	62	87	149	192	252	324	576	970
减速电机输出扭矩 Torque For Gearbox(mN.m)	1906	3168	3500	3500	3500	3500	3500	3500	3500
减速电机总高度 Total Length(mm)	99.5								
减速电机总重量 Total Weight(g)	240.2								
减速器长度 Gearbox Length(mm)	46								
减速后速度 Speed After Gearbox	24.13	14.52	10.34	6.04	4.69	3.57	2.78	1.56	0.93
背隙 (无负载时) Backlash At No-load	1°~1.5°								
效率 Efficiency	73%	73%	70%	67%	65%	63%	61%	45%	25%

## 减速电机性能参数 (28HS5401) / Geared Stepper Motor Specifications

减速比 Reduction Ratio	37.3	62	87	149	192	252	324	576	970
减速电机输出扭矩 Torque For Gearbox(mN.m)	2586	3500	3500	3500	3500	3500	3500	3500	3500
减速电机总高度 Total Length(mm)	112								
减速电机总重量 Total Weight(g)	310.2								
减速器长度 Gearbox Length(mm)	46								
减速后速度 Speed After Gearbox	24.13	14.52	10.34	6.04	4.69	3.57	2.78	1.56	0.93
背隙 (无负载时) Backlash At No-load	1°~1.5°								
效率 Efficiency	73%	73%	70%	67%	65%	63%	61%	45%	25%

# 尺寸图 / Dimensions

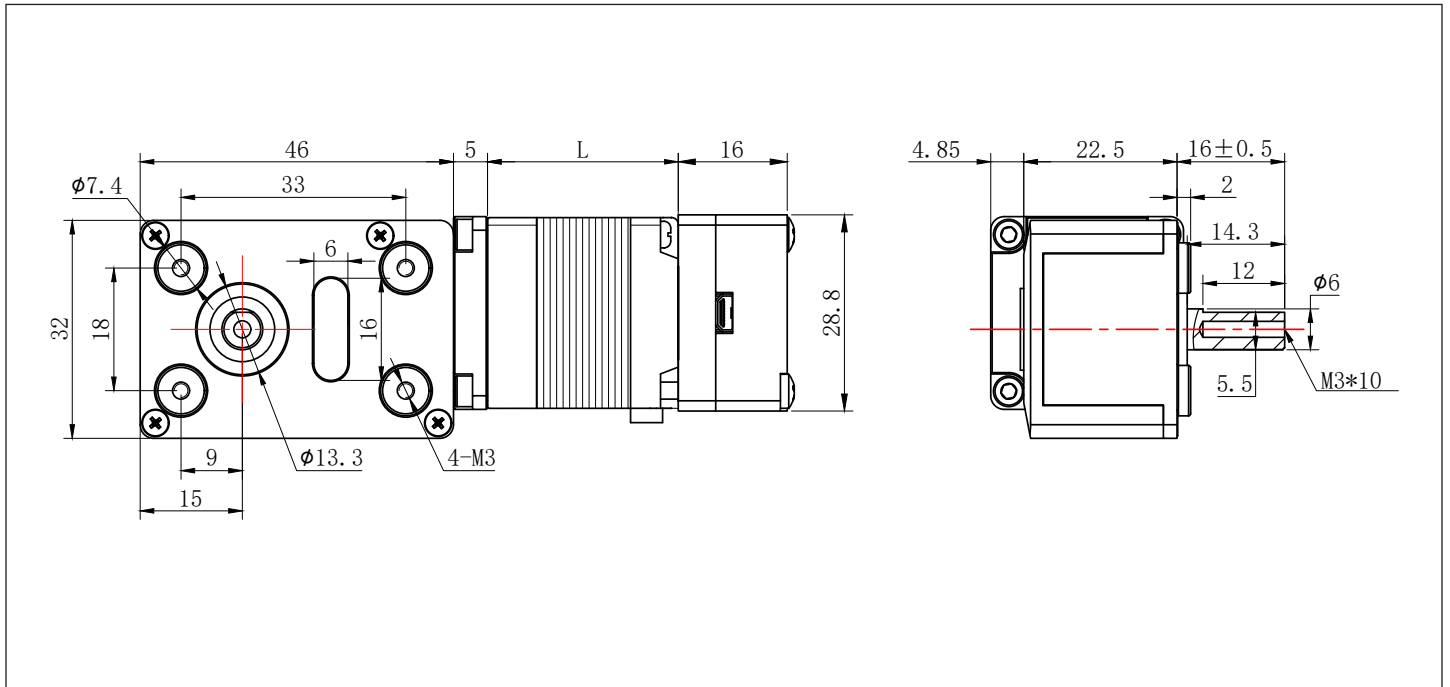

# 35 一体式步进驱动器 (闭环脉冲型)

35 Integrated Stepper Motor Driver (Closed Loop Pulse Control)

## UMLP35

### 产品概述 / Product Description

UMLP35 一体式脉冲型闭环步进驱动器是重庆优摩特科技有限公司最新推出的一款新型电机驱动一体化电机驱动器，采用最新专用电机控制数字信号处理器，提升电机的综合性能、降低电机的发热程度和减小电机的振动，采用电机和驱动器一体式设计，安装更加紧凑，减少外界干扰。

UMLP35 带串口调试功能，通讯采用 MINI USB 接口，用户可通过 PC 端上位机调试软件设置细分、电流、工作模式等多种参数，极大地丰富了产品的实用功能，能够满足绝大多数场合的应用。

UMLP35 integrated closed loop pulse stepper motor driver is new designed for open-loop stepper motor by UMot. It adopts the latest dedicated motor control. It uses a digital signal processor to improve the performance of the motor, reduce the heat and vibration of the motor. It adopts an integrated design of the motor and driver to install more compact.

UMLP35 has serial port debugging function, and the communication adopts MINI USB interface. Users can set various parameters such as subdivision, current, working mode, etc. through PC host debugging software, which greatly enriches the practical functions of the product and can meet various application.

### 产品特点 / Feature

- 电机和驱动一体化，节省接线人工  
No need to wire stepper motor with driver
- 体积小，便于安装  
Small size, easy install
- 新一代 32 位 DSP 技术，平稳性佳、兼容性强、性价比高  
New generation of 32-bit DSP technology, with good stability, strong compatibility and high cost performance
- 光隔离差分信号输入  
Optically isolated differential signal input
- 内置微细分，低速平稳性极佳  
Micro segmentation setting inside, stable work at low speed
- 脉冲响应频率最高可达 200KHz (更高可改)  
Impulse response frequency max to 200KHz  
(The max one can be changed)
- 细分设定范围 200-60000 (可通过上位机设置任意微细分)  
Subdivision setting range 200-60000  
(Any micro-segment can be set through the controller)
- 精密电流控制使电机发热大幅降低  
Precision current control significantly reduces motor heating
- 低振动低噪声  
Low vibration and low noise
- 具有过压、欠压、缺相等报警保护功能  
Overvoltage, undervoltage, phase loss protection
- 输入电压范围: DC12V~40V  
Input voltage range: DC12V-40V
- 默认有效电流 1.0A (也可通过上位机设置任意电流值)  
The default effective current is 1.0A  
(any current value can also be set through the controller)



### 应用领域 / Application

适合各种中小型自动化设备和仪器，例如：医疗设备、检测设备、打标机、绘图仪等。满足客户低噪声、低发热、布线方便，抗干扰性更强等要求。

Suitable for various small and medium-sized automation equipment and instruments, such as: medical equipment, testing equipment, marking machines, plotters, etc. Satisfy customers with low noise, low heat, convenient wiring and anti-interference performance stronger requirements.

## 电气指标 / Specifications

说明 Description	UMLP35			
	最小值 Minimum	典型值 Normally	最大值 Max	单位 unit
输入电源电压 Input Voltage	12	24	40	VDC
控制信号输入电流 Input signal current	7	10	16	mA
步进脉冲频率 Frequency	0	-	200	KHz
绝缘电阻 Insulation resistance	50			MΩ

## 使用环境及参数 / Working Environment

冷却方式 Cooling		自然冷却、风扇散热 Natural cooling, air cooling
使用环境 Working Environment	场合 Environment	不能放在其他发热的设备旁, 要避免粉尘、油雾、腐蚀性气体, 湿度太大及强振动场所, 禁止有可燃气体和导电灰尘 Do not work to other heating equipment. Avoid dust, oil mist, corrosive gases, places with excessive humidity and strong vibrations. No combustible gases are allowed. body and conductive dust
	温度 Temperature	0-50°C
	湿度 Humidity	40-90%RH
	振动 Vibration	10~55Hz/0.15mm
保存温度 Storage Temperature		-20°C ~65°C

## 接口示意图 / Interface diagram

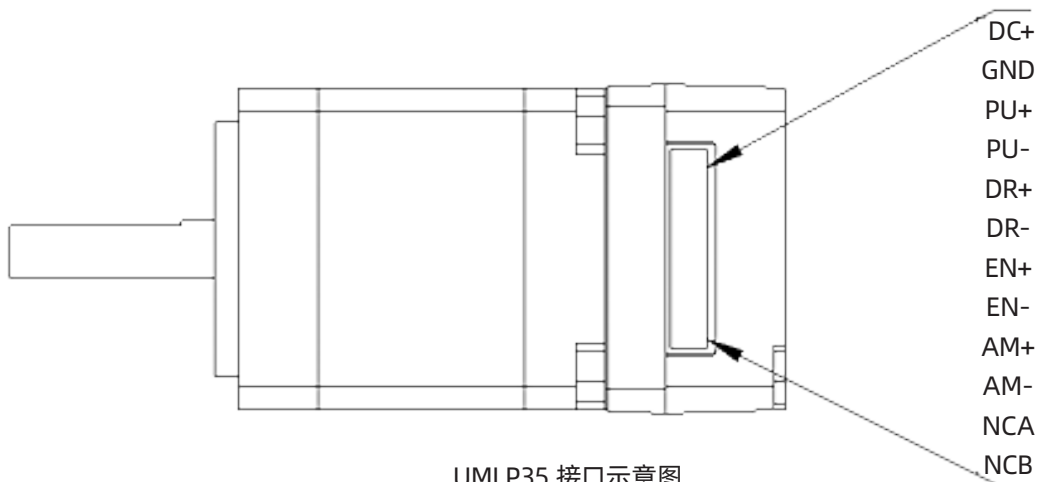

UMLP35 接口示意图  
UMLP35 Interface diagram

## 接口描述 /Interface description

UMLP35 一体式脉冲型开环步进驱动器的电源接口与、信号控制接口和输出信号接口采用 JST1.25-12P 针座。接口具体定义看以下几个小节介绍。

The power interface, signal control interface and output signal interface of UMLP35 integrated pulse closed-loop stepper driver adopt JST1.25-12P pin socket. For the specific definition of the interface, please refer to the introduction of the following sections.

## 电源输入接口 /Power input interface

名称 Item		说明 Description	功能 Function
VDC	DC+	电源接口 Power connector	电源输入 DC12V~40V Power input DC12V-40V
	GND		

## 控制信号接口 /Control Signal Interface

名称 Item	功能 Function
PU+	脉冲控制信号: +5V-+24V 均可驱动, 上升沿有效, 每当脉冲由低变高时, 电机走一微步。为了可靠响应脉冲信号, 脉冲宽度应大于 2.5 $\mu$ s。 Pulse control signal: +5V-+24V can be driven, the rising edge is valid, every time the pulse changes from low to high, the motor takes a micro step. In order to respond reliably to pulse signals, the pulse width should be greater than 2.5 $\mu$ s.
PU-	
DR+	方向控制信号: +5V-+24V 均可驱动, 高 / 低电平信号。为保证电机可靠换向, 方向信号应先于脉冲信号至少 50 $\mu$ s 建立。 Direction control signal: +5V-+24V can be driven, high/low level signal. In order to ensure reliable commutation of the motor, the direction signal should first It takes at least 50 $\mu$ s for the pulse signal to establish.
DR-	
EN+	使能控制信号: +5V-+24V 均可驱动, 高 / 低电平信号。用于使能或禁止电机的运行。当 EN+ 接 +5V, EN- 接低电平时, 驱动器将切断电机各相的电流使电机处于自由状态, 此时步进脉冲不被响应。当不需用此功能时, 使能信号端悬空即可。另外, EN 端还可用于清除超差报警信号。 Enable control signal: +5V-+24V can be driven, high/low level signal. Used to enable or disable the operation of the motor. When EN+ When connected to +5V and EN- to low level, the driver will cut off the current of each phase of the motor to make the motor in a free state. At this time, the step pulse Not responded to. When this function is not needed, the enable signal terminal can be left floating. In addition, the EN terminal can also be used to clear the out-of-tolerance alarm signal.
EN-	

## 输出信号接口 / Output signal interface

输出信号接口默认作为报警输出功能使用，当发生过压、欠压、缺相报警时，输出信号有效。此外，输出接口也可通过 PC 端上位机软件设置为到位输出、刹车控制输出功能使用，用户可根据实际使用情况做相应设置。

The output signal interface is used as the alarm output function by default. When overvoltage, undervoltage, and phase loss alarm occur, the output signal is valid. In addition, the output interface can also be set to in-position output and brake control output functions through the PC host software. Users can make corresponding settings according to actual usage.

名称 Item	功能 Function
AM+	报警信号输出: 过压、欠压、缺相报警发生时, 报警信号输出有效; Alarm signal output: When overvoltage, undervoltage, or phase loss alarm occurs, the alarm signal output is valid; 常开或常闭接法见 3.4 小节内描述; The normally open or normally closed connection method is described in Section 3.4;
AM-	最大驱动电流 50mA。 Maximum drive current 50mA。

名称 Item	功能 Function	说明 Description
绿色 LED Green LED  红色 LED Red LED	电源、报警指示灯、保存参数功能指示、恢复出厂设置功能指示、拨码状态切换指示; Power supply, alarm indicator light, save parameter function Can indicate, restore factory settings function instructions, Dial status switching indication;	通电正常时绿灯常亮, 红灯熄灭。保存参数、恢复出厂设置、拨码状态发生切换、设备发生异常时, 红绿灯交替闪烁报警, 其闪烁规律查看第五章; When the power is on normally, the green light is always on and the red light is off. When saving parameters, restoring factory settings, switching the dial status, or abnormal equipment occurs, the red and green lights flash alternately to alarm. For the flashing pattern, please refer to Chapter 5

## 输入控制信号接口电路 / Input control signal interface circuit

UMLP35 驱动器控制信号端采用差分式接口电路，可适用差分信号、单端共阴及共阳等接口，内置高速光电耦合器，在环境恶劣的场合，抗干扰能力强。接口电路示意图如图 3.2 所示。

The UMLP35 driver control signal end adopts a differential interface circuit, which can be used for differential signals, single-ended common cathode and common anode interfaces. It has a built-in high-speed photocoupler, which can be used in harsh environments.

Strong anti-interference ability. The schematic diagram of the interface circuit is shown in Figure 3.2.



图 3.2 输入接口电路  
Figure 3.2 Input interface circuit

## 尺寸图 / Dimensions

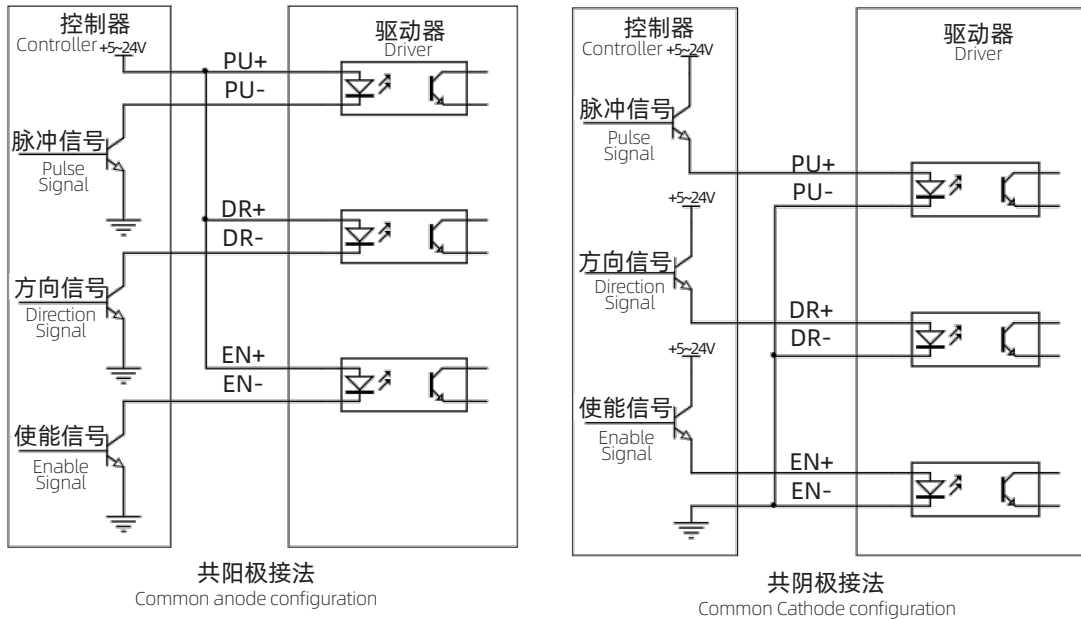
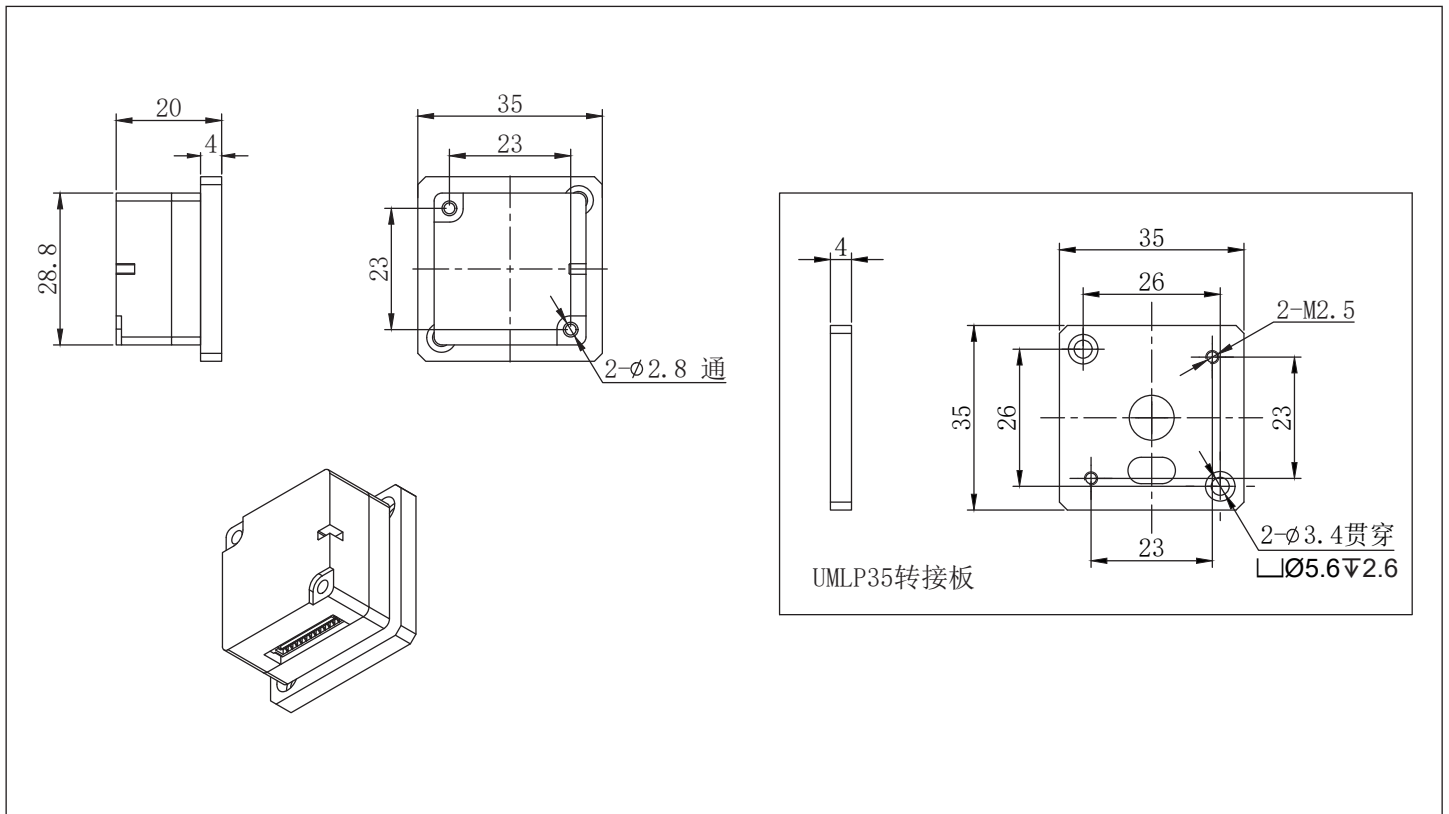

# 35 传动蜗轮蜗杆减速一体式步进电机 (闭环脉冲型)

35 Worm Geared Stepper Motor with Integrated Driver (Closed Loop Pulse Control)  
(Backlash  $\leq 1.5^\circ$ )



## 技术参数 / Technical Data

Model No.	额定电压 Rated Voltage (V)	每相电流 Current /Phase (A)	每相电阻 Resistance /Phase ( $\Omega$ )	每相电感 Inductance /Phase (mH)	保持转矩 Holding Torque (mN.m)	引出线数 #of Leads	转动惯量 Rotor Inertia (g-cm <sup>2</sup> )	重量 Weight (kg)	机身长度 (L) Length(L) (mm)	适配减速比 Max. Gear Ratio
35HS2408	4.5	1.0	4.5	5.5	200	4	25	0.15	28	$\leq 1: 970$
35HS5401	4.5	1.0	4.5	7	250	4	35	0.25	38.5	$\leq 1: 970$

## 减速电机性能参数 (35HS2408) / Geared Stepper Motor Specifications

减速比 Reduction Ratio	37.3	62	87	149	192	252	324	576	970
减速电机输出扭矩 Torque For Gearbox(mN.m)	3500	3500	3500	3500	3500	3500	3500	3500	3500
减速电机总高度 Total Length(mm)	99								
减速电机总重量 Total Weight(g)	282								
减速器长度 Gearbox Length(mm)	46								
减速后速度 Speed After Gearbox	24.13	14.52	10.34	6.04	4.69	3.57	2.78	1.56	0.93
背隙 (无负载时) Backlash At No-load	1°~1.5°								
效率 Efficiency	73%	73%	70%	67%	65%	63%	61%	45%	25%

## 减速电机性能参数 (35HS5401) / Geared Stepper Motor Specifications

减速比 Reduction Ratio	37.3	62	87	149	192	252	324	576	970
减速电机输出扭矩 Torque For Gearbox(mN.m)	3500	3500	3500	3500	3500	3500	3500	3500	3500
减速电机总高度 Total Length(mm)	109.5								
减速电机总重量 Total Weight(g)	382								
减速器长度 Gearbox Length(mm)	46								
减速后速度 Speed After Gearbox	24.13	14.52	10.34	6.04	4.69	3.57	2.78	1.56	0.93
背隙 (无负载时) Backlash At No-load	1°~1.5°								
效率 Efficiency	73%	73%	70%	67%	65%	63%	61%	45%	25%

# 尺寸图 / Dimensions

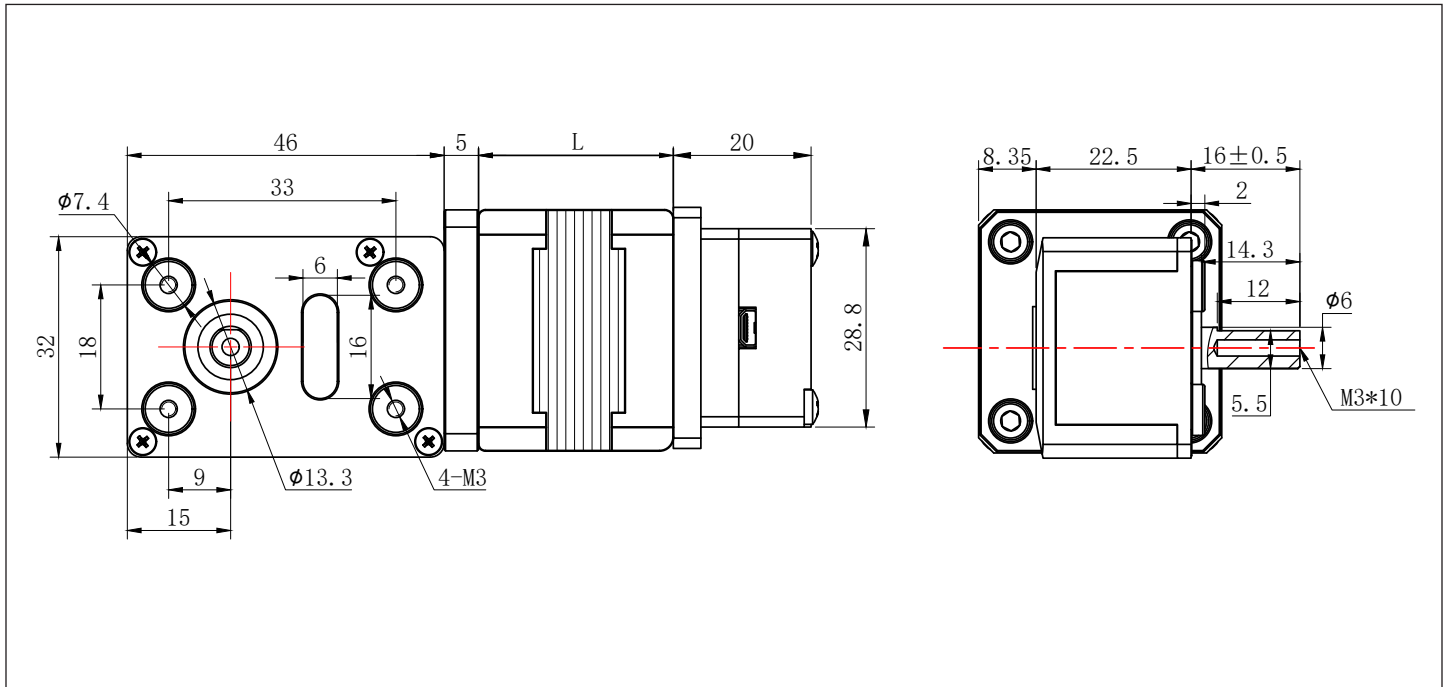

# 42 一体式步进驱动器 (闭环脉冲型)

42 Integrated Stepper Motor Driver (Closed Loop Pulse Control)

## UMLP42

### 产品概述 /Product Description

UMLP42 一体式脉冲型闭环步进驱动器是重庆优摩特科技有限公司最新推出的一款新型电机驱动一体化电机驱动器，采用最新专用电机控制数字信号处理器，提升电机的综合性能、降低电机的发热程度和减小电机的振动，采用电机和驱动器一体式设计，安装更加紧凑，减少外界干扰。

UMLP42 integrated closed loop pulse stepper motor driver is new designed for open-loop stepper motor by UMot. It adopts the latest dedicated motor control. It uses a digital signal processor to improve the performance of the motor, reduce the heat and vibration of the motor. It adopts an integrated design of the motor and driver to install more compact.

### 产品特点 /Feature

- 电机和驱动一体化，节省接线人工  
No need to wire stepper motor with driver
- 体积小，便于安装  
Small size, easy install
- 新一代 32 位 DSP 技术，平稳性佳、兼容性强、性价比高  
New generation of 32-bit DSP technology, with good stability, strong compatibility and high cost performance
- 外置拨码设置驱动器电流、工作模式、细分  
External dial code sets driver current, working mode, subdivision
- 光隔离差分信号输入  
Optically isolated differential signal input
- 内置微细分，低速平稳性极佳  
Micro segmentation setting inside, stable work at low speed
- 脉冲响应频率最高可达 200KHz  
Impulse response frequency max to 200KHz
- 细分设定范围 200-40000、自发脉冲速度设定范围 30-720r/min  
Subdivision setting range 200-40000, spontaneous pulse speed setting range 30-720r/min
- 精密电流控制使电机发热大幅降低  
Precision current control significantly reduces motor heating
- 低振动低噪声  
Low vibration and low noise
- 具有过压、欠压、缺相等报警保护功能  
Overvoltage, undervoltage, phase loss protection
- 输入电压范围：DC12V~40V  
Input voltage range: DC12V-40V



### 应用领域 /Application

适合各种中小型自动化设备和仪器，例如：医疗设备、检测设备、打标机、绘图仪等。满足客户低噪声、低发热、布线方便，抗干扰性更强等要求。

Suitable for various small and medium-sized automation equipment and instruments, such as: medical equipment, testing equipment, marking machines, plotters, etc. Satisfy customers with low noise, low heat, convenient wiring and anti-interference performance stronger requirements.

### 电气指标 /Specifications

说明 Description	UMLP42			
	最小值 Minimum	典型值 Normally	最大值 Max	单位 unit
输入电源电压 Input Voltage	12	24	40	VDC
控制信号输入电流 Input signal current	7	10	16	mA
步进脉冲频率 Frequency	0		200	KHz
绝缘电阻 Insulation resistance	50			MΩ

## 使用环境及参数 / Working Environment

冷却方式 Cooling		自然冷却、风扇散热 Natural cooling, air cooling
使用环境 Working Environment	场合 Environment	不能放在其他发热的设备旁, 要避免粉尘、油雾、腐蚀性气体, 湿度太大及强振动场所, 禁止有可燃气体和导电灰尘 Do not work to other heating equipment. Avoid dust, oil mist, corrosive gases, places with excessive humidity and strong vibrations. No combustible gases are allowed. body and conductive dust
	温度 Temperature	0-50°C
	湿度 Humidity	40-90%RH
	振动 Vibration	10~55Hz/0.15mm
保存温度 Storage Temperature		-20°C ~65°C

## 控制信号接口 / Control Signal Interface

名称 Item	功能 Function
PU+	脉冲控制信号: +5V-+24V 均可驱动, 上升沿有效, 每当脉冲由低变高时, 电机走一微步。为了可靠响应脉冲信号, 脉冲宽度应大于 2.5 $\mu$ s。
PU-	Pulse control signal: +5V-+24V can be driven, the rising edge is valid, every time the pulse changes from low to high, the motor takes a micro step. In order to respond reliably to pulse signals, the pulse width should be greater than 2.5 $\mu$ s.
DR+	方向控制信号: +5V-+24V 均可驱动, 高 / 低电平信号。为保证电机可靠换向, 方向信号应先于脉冲信号至少 50 $\mu$ s 建立。
DR-	Direction control signal: +5V-+24V can be driven, high/low level signal. In order to ensure reliable commutation of the motor, the direction signal should first It takes at least 50 $\mu$ s for the pulse signal to establish.
EN+	使能控制信号: +5V-+24V 均可驱动, 高 / 低电平信号。用于使能或禁止电机的运行。当 EN+ 接 +5V, EN- 接低电平时, 驱动器将切断电机各相的电流使电机处于自由状态, 此时步进脉冲不被响应。当不需用此功能时, 使能信号端悬空即可。
EN-	Enable control signal: +5V-+24V can be driven, high/low level signal. Used to enable or disable the operation of the motor. When EN+ When connected to +5V and EN- to low level, the driver will cut off the current of each phase of the motor to make the motor in a free state. At this time, the step pulse Not responded to. When this function is not needed, the enable signal terminal can be left floating.

## 输出信号接口 /Output signal interface

输出信号接口默认作为报警输出功能使用，当发生过压、欠压、缺相、位置超差报警时，输出信号有效。

It's used for alarm output. When overvoltage, undervoltage, phase loss, or position out-of-tolerance alarm occurs, the output signal is valid.

名称 Item	功能 Function
AM+	报警信号输出: 过压、欠压、缺相报警发生时, 报警信号输出有效; Alarm signal output: When overvoltage, undervoltage, or phase loss alarm occurs, the alarm signal output is valid;
AM-	常开或常闭接法见 3.4 小节内描述; The normally open or normally closed connection method is described in Section 3.4; 最大驱动电流 50mA。 Maximum drive current 50mA。

## 电源输入接口 /Power input interface

名称 Item	说明 Description	功能 Function
VDC	电源接口 Power connector	电源输入 DC12V~40V Power input DC12V-40V

## 状态指示 /Status Indication

UMLP42 一体式脉冲型闭环步进驱动器的指示灯为内缩式贴片绿色 LED，其基本定义如下表所示。

UMLP42 indicator light is a retracted SMD green LED, and its basic definition is as shown in the table below.

名称 Item	功能 Function	说明 Description
绿色 LED Green LED	电源、报警指示灯、保存参数功能指示、恢复出厂设置功能指示、拨码状态切换指示; Power supply, alarm indicator light, save parameter function Can indicate, restore factory settings function instructions, Dial status switching indication;	通电正常时灯常亮, 报警、保存参数、恢复出厂设置、拨码状态发生切换时闪烁, 其闪烁规律查看第六章; When the power is normal, the light is always on, alarm and save parameters, restore factory settings, dialing status Flashes when switching occurs. Check the flashing pattern. See Chapter 6;

## 输入控制信号接口电路 / Input control signal interface circuit

UMLP42 驱动器控制信号端采用差分式接口电路，可适用差分信号、单端共阴及共阳等接口，内置高速光电耦合器，在环境恶劣的场合，抗干扰能力强。接口电路示意图如图 3.2 所示。

The UMLP42 driver control signal end adopts a differential interface circuit, which can be used for differential signals, single-ended common cathode and common anode interfaces. It has a built-in high-speed photocoupler, which can be used in harsh environments.

Strong anti-interference ability. The schematic diagram of the interface circuit is shown in Figure 3.2.



图 3.2 输入接口电路  
Figure 3.2 Input interface circuit

○ 注意：UMLP42 为 5V-24V 通用驱动器，因此信号控制端不串电阻。

Note: UMLP42 is a 5V-24V universal driver, so there is no resistor in the signal control terminal.

## 尺寸图 / Dimensions

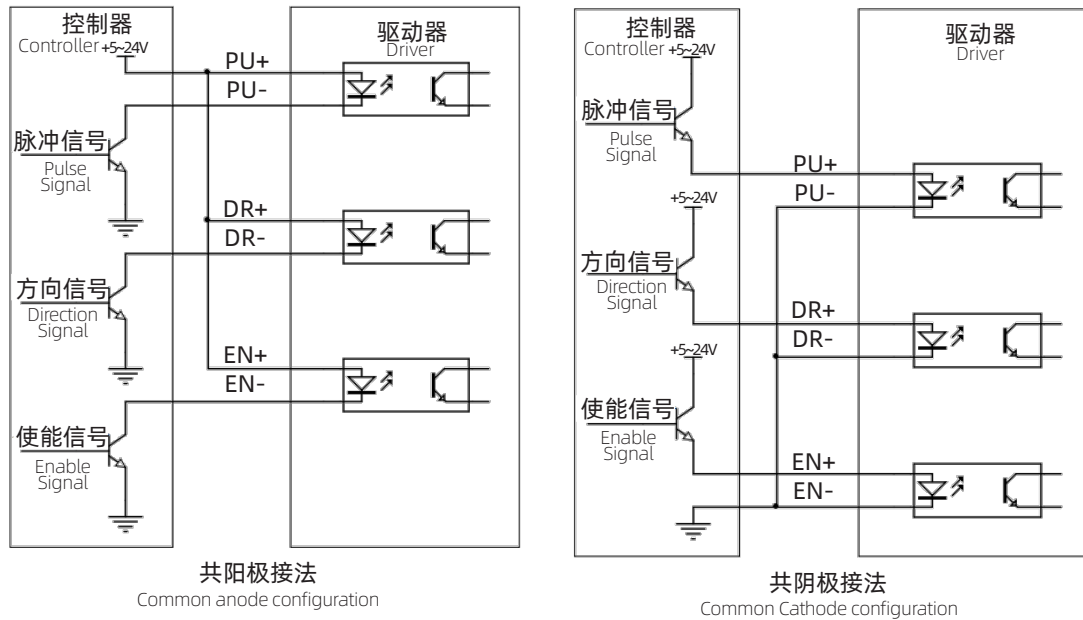
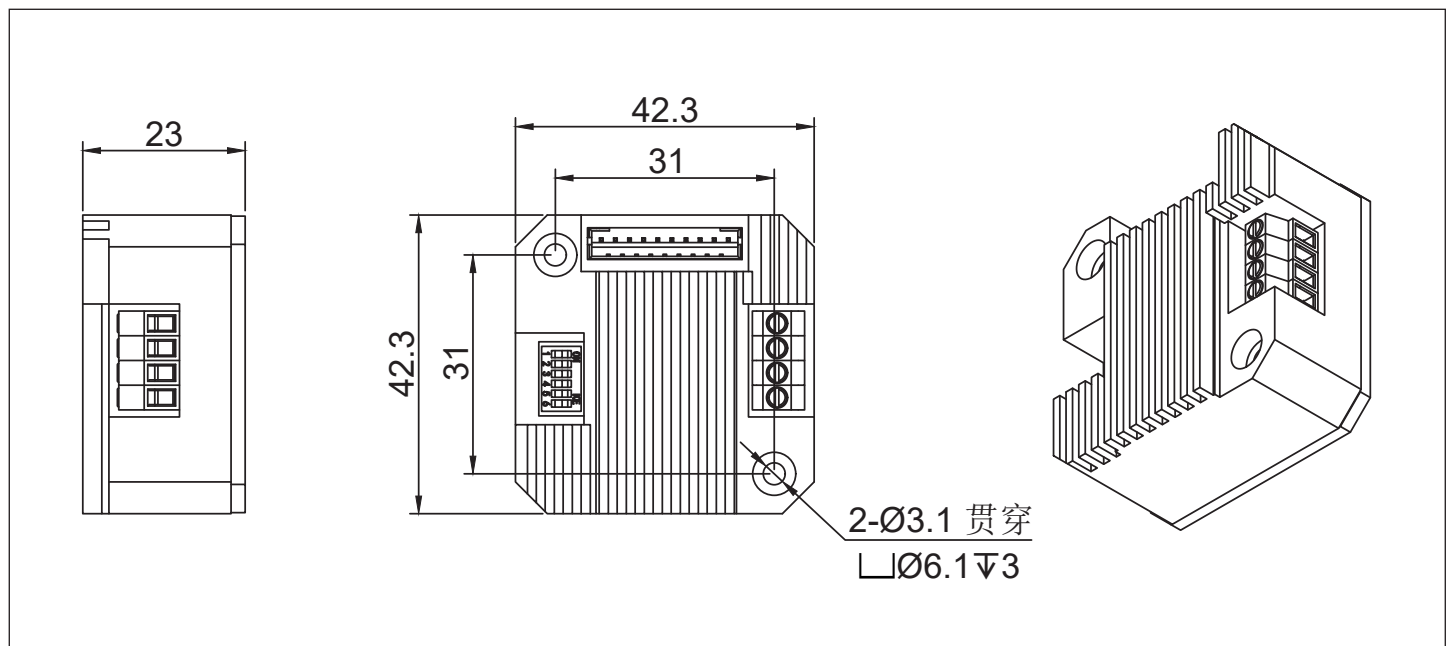

# 42 传动蜗轮蜗杆减速一体式步进电机 (闭环脉冲型)

42Worm Geared Stepper Motor with Integrated Driver (Closed Loop Pulse Control)  
(Backlash  $\leq 1.5^\circ$ )



## 技术参数 / Technical Data

Model No.	额定电压 Rated Voltage (V)	每相电流 Current /Phase (A)	每相电阻 Resistance /Phase ( $\Omega$ )	每相电感 Inductance /Phase (mH)	保持转矩 Holding Torque (mN.m)	引出线数 #of Leads	转动惯量 Rotor Inertia (g-cm <sup>2</sup> )	重量 Weight (kg)	机身长度 (L) Length(L) (mm)	适配减速比 Max. Gear Ratio
42HSC1409	2.93	1.33	2.2	3.5	270	4	30	0.22	34	$\leq 1: 505$
42HSC4409	2.5	1.5	1.65	3.3	380	4	40	0.3	40	$\leq 1: 505$

## 减速电机性能参数 (42HSC1409) / Geared Stepper Motor Specifications

减速比 Reduction Ratio	17	31	50	100	290	505
减速电机输出扭矩 Torque For Gearbox(mN.m)	1100	2200	3000	5000	5000	5000
减速电机总高度 Total Length(mm)	123					
减速电机总重量 Total Weight(g)	637					
减速器长度 Gearbox Length(mm)	66					
减速后速度 Speed After Gearbox	52.94	29.03	18.00	9.00	3.10	1.78
背隙 (无负载时) Backlash At No-load	1°~1.5°					
效率 Efficiency	81%	81%	73%	73%	66%	50%

## 减速电机性能参数 (42HSC4409) / Geared Stepper Motor Specifications

减速比 Reduction Ratio	17	31	50	100	290	505
减速电机输出扭矩 Torque For Gearbox(mN.m)	1100	2200	3000	5000	5000	5000
减速电机总高度 Total Length(mm)	129					
减速电机总重量 Total Weight(g)	717					
减速器长度 Gearbox Length(mm)	66					
减速后速度 Speed After Gearbox	52.94	29.03	18.00	9.00	3.10	1.78
背隙 (无负载时) Backlash At No-load	1°~1.5°					
效率 Efficiency	81%	81%	73%	73%	66%	50%



# 42精密方形蜗轮蜗杆减速一体式步进电机 (闭环脉冲型)

42 Square Flange Worm Geared Stepper Motor with Integrated Driver (Closed Loop Pulse Control)  
(Backlash ≤ 15 arcmin)

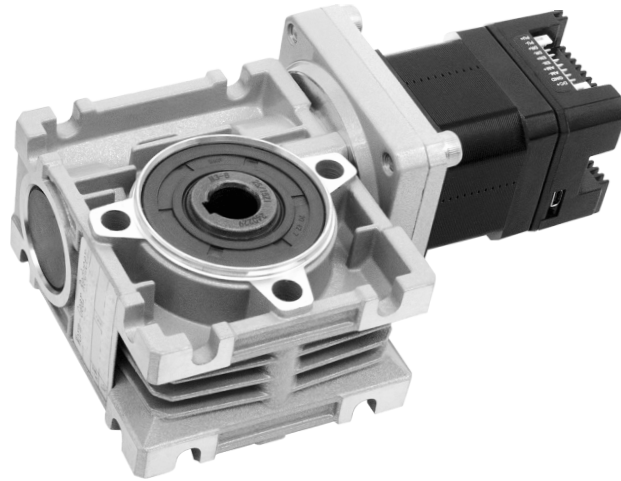

## 技术参数 / Technical Data

Model No.	额定电压 Rated Voltage (V)	每相电流 Current /Phase (A)	每相电阻 Resistance /Phase (Ω)	每相电感 Inductance /Phase (mH)	保持转矩 Holding Torque (mN.m)	引出线数 #of Leads	转动惯量 Rotor Inertia (g-cm <sup>2</sup> )	重量 Weight (kg)	机身长度 (L) Length(L) (mm)	适配减速比 Max. Gear Ratio
42HSC4409	2.75	1.5	1.65	3.3	380	4	40	0.30	40	≤ 1: 60
42HSC6411	2.77	1.68	1.65	2.8	500	4	68	0.35	48	≤ 1: 60

## 减速电机性能参数 (42HSC4409) / Geared Stepper Motor Specifications

减速比 Reduction Ratio	5	7.5	10	15	20	25	30	40	50	60
减速电机输出扭矩 Torque For Gearbox(mN.m)	1763	2583	3362	4797	6068	7175	8118	10000	10000	13284
减速电机总高度 Total Length(mm)	150.5									
减速电机总重量 Total Weight(g)	1037									
减速器长度 Gearbox Length(mm)	87.5									
减速后速度 Speed After Gearbox	180	120	90	60	45	36	30	22.5	18	15
背隙 (无负载时) Backlash At No-load	15' ~18'									
效率 Efficiency	86%	84%	82%	78%	74%	70%	66%	61%	57%	54%

## 减速电机性能参数 (42HSC6411) / Geared Stepper Motor Specifications

减速比 Reduction Ratio	5	7.5	10	15	20	25	30	40	50	60
减速电机输出扭矩 Torque For Gearbox(mN.m)	1800	2600	3400	4900	6100	7875	8200	10000	12000	14000
减速电机总高度 Total Length(mm)	158.5									
减速电机总重量 Total Weight(g)	1137									
减速器长度 Gearbox Length(mm)	87.5									
减速后速度 Speed After Gearbox	180	120	90	60	45	36	30	22.5	18	15
背隙 (无负载时) Backlash At No-load	15' ~18'									
效率 Efficiency	86%	84%	82%	78%	74%	70%	66%	61%	57%	54%

# 尺寸图 / Dimensions

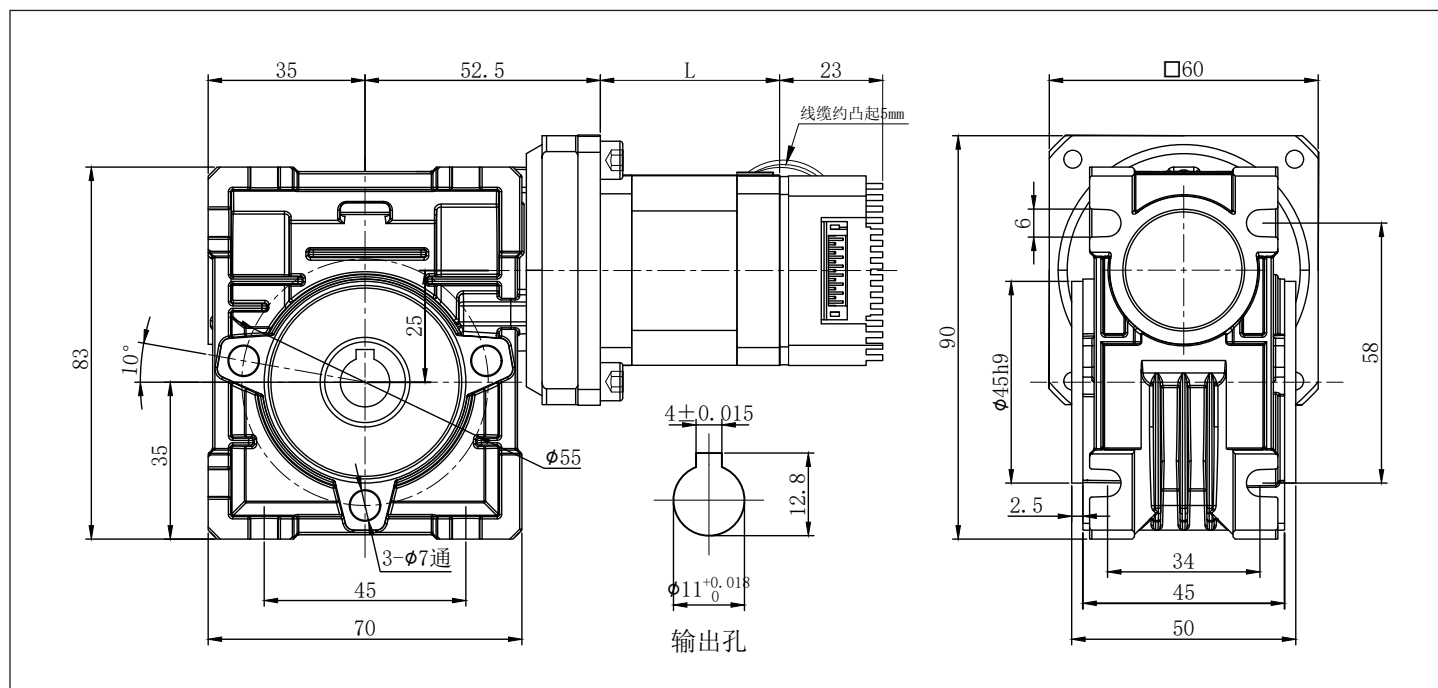

# 57 一体式步进驱动器 (闭环脉冲型)

57 Integrated Stepper Motor Driver (Closed Loop Pulse Control)

## UMLP57

### 产品概述 /Product Description

UMLP57 一体式脉冲型闭环步进驱动器是重庆优摩特科技有限公司最新推出的一款新型电机驱动一体化电机驱动器, 采用最新专用电机控制数字信号处理器, 提升电机的综合性能、降低电机的发热程度和减小电机的振动, 采用电机和驱动器一体式设计, 安装更加紧凑, 减少外界干扰。

UMLP57 integrated closed loop pulse stepper motor driver is new designed for open-loop stepper motor by UMot. It adopts the latest dedicated motor control. It uses a digital signal processor to improve the performance of the motor, reduce the heat and vibration of the motor. It adopts an integrated design of the motor and driver to install more compact.

### 产品特点 /Feature

- 电机和驱动一体化, 节省接线人工  
No need to wire stepper motor with driver
- 体积小, 便于安装  
Small size, easy install
- 新一代 32 位 DSP 技术, 平稳性佳、兼容性强、性价比高  
New generation of 32-bit DSP technology, with good stability, strong compatibility and high cost performance
- 外置拨码设置驱动器电流、细分  
External dial code sets driver current, subdivision
- 光隔离差分信号输入  
Optically isolated differential signal input
- 内置微细分, 低速平稳性极佳  
Micro segmentation setting inside, stable work at low speed
- 脉冲响应频率最高可达 200KHz  
Impulse response frequency max to 200KHz
- 细分设定范围 200-60000  
Subdivision setting range 200-60000
- 精密电流控制使电机发热大幅降低  
Precision current control significantly reduces motor heating
- 低振动低噪声  
Low vibration and low noise
- 具有过压、欠压、缺相等报警保护功能  
Overvoltage, undervoltage, phase loss protection
- 输入电压范围: DC12V~50V  
Input voltage range: DC12V-50V



### 应用领域 /Application

适合各种中小型自动化设备和仪器, 例如: 医疗设备、检测设备、打标机、绘图仪等。满足客户低噪声、低发热、布线方便, 抗干扰性更强等要求。

Suitable for various small and medium-sized automation equipment and instruments, such as: medical equipment, testing equipment, marking machines, plotters, etc. Satisfy customers with low noise, low heat, convenient wiring and anti-interference performance stronger requirements.

### 电气指标 /Specifications

说明 Description	UMLP57			
	最小值 Minimum	典型值 Normally	最大值 Max	单位 unit
输入电源电压 Input Voltage	12	24	50	VDC
控制信号输入电流 Input signal current	7	10	16	mA
步进脉冲频率 Frequency	0		200	KHz
绝缘电阻 Insulation resistance	50			MΩ

## 使用环境及参数 / Working Environment

冷却方式 Cooling		自然冷却、风扇散热 Natural cooling, air cooling
使用环境 Working Environment	场合 Environment	不能放在其他发热的设备旁, 要避免粉尘、油雾、腐蚀性气体, 湿度太大及强振动场所, 禁止有可燃气体和导电灰尘 Do not work to other heating equipment. Avoid dust, oil mist, corrosive gases, places with excessive humidity and strong vibrations. No combustible gases are allowed. body and conductive dust
	温度 Temperature	0-50°C
	湿度 Humidity	40-90%RH
	振动 Vibration	10~55Hz/0.15mm
保存温度 Storage Temperature		-20°C ~65°C

## 接口描述 / Application

UMLP57 一体式脉冲型闭环步进驱动器的电源接口采用 XH2.54-2P 针座, 信号控制接口采用 PHB2.0-6P 针座, 电机接口采用 3.5-4P 针座, 出厂时已正确接线。接口具体定义看以下几个小节介绍。

The UMLP57 power interface integrated pulse closed-loop stepper driver adopts XH2.54-2P pin holder, the signal control interface adopts PHB2.0-6P pin holder, and the motor interface adopts 3.5-4P pin holder. The wiring is correct before leaving the factory. For the specific definition of the interface, see the introduction in the following sections.

## 控制信号接口 / Control Signal Interface

名称 Item	功能 Function
PU+	脉冲控制信号: +5V-+24V 均可驱动, 上升沿有效, 每当脉冲由低变高时, 电机走一微步。为了可靠响应脉冲信号, 脉冲宽度应大于 2.5μs。
PU-	Pulse control signal: +5V-+24V can be driven, the rising edge is valid, every time the pulse changes from low to high, the motor takes a micro step. In order to respond reliably to pulse signals, the pulse width should be greater than 2.5μs.
DR+	方向控制信号: +5V-+24V 均可驱动, 高 / 低电平信号。为保证电机可靠换向, 方向信号应先于脉冲信号至少 50μs 建立。
DR-	Direction control signal: +5V-+24V can be driven, high/low level signal. In order to ensure reliable commutation of the motor, the direction signal should first It takes at least 50μs for the pulse signal to establish.
EN+	使能控制信号: +5V-+24V 均可驱动, 高 / 低电平信号。用于使能或禁止电机的运行。当 EN+ 接 +5V, EN- 接低电平时, 驱动器将切断电机各相的电流使电机处于自由状态, 此时步进脉冲不被响应。当不需用此功能时, 使能信号端悬空即可。
EN-	Enable control signal: +5V-+24V can be driven, high/low level signal. Used to enable or disable the operation of the motor. When EN+ When connected to +5V and EN- to low level, the driver will cut off the current of each phase of the motor to make the motor in a free state. At this time, the step pulse Not responded to. When this function is not needed, the enable signal terminal can be left floating.

## 输出信号接口 /Output signal interface

输出信号接口默认作为报警输出功能使用，当发生过压、欠压、缺相、位置超差报警时，输出信号有效。此外，用户可根据实际使用情况做相应设置。

It's used for alarm output. When overvoltage, undervoltage, phase loss, or position out-of-tolerance alarm occurs, the output signal is valid. In addition, users can make corresponding settings according to actual usage conditions.

名称 Item	功能 Function
AM+	报警信号输出: 过压、欠压、缺相报警发生时, 报警信号输出有效; Alarm signal output: When overvoltage, undervoltage, or phase loss alarm occurs, the alarm signal output is valid;
AM-	常开或常闭接法见 3.4 小节内描述; The normally open or normally closed connection method is described in Section 3.4; 最大驱动电流 50mA。 Maximum drive current 50mA。
A B	485 通讯接口 A、B 端, 预留端口, 此型号不支持 RS485, 不用接 485 communication interface A and B are reserved ports. This model does not support RS485, so there is no need to connect them.

## 电源输入接口 /Power input interface

名称 Item	说明 Description	功能 Function
VDC	电源接口 Power connector	电源输入 DC12V~50V Power input DC12V-50V

## 输入控制信号接口电路 / Input control signal interface circuit

UMLP57 驱动器控制信号端采用差分式接口电路，可适用差分信号、单端共阴及共阳等接口，内置高速光电耦合器，在环境恶劣的场合，抗干扰能力强。接口电路示意图如图 3.2 所示。

The UMLP57 driver control signal end adopts a differential interface circuit, which can be used for differential signals, single-ended common cathode and common anode interfaces. It has a built-in high-speed photocoupler, which can be used in harsh environments.

Strong anti-interference ability. The schematic diagram of the interface circuit is shown in Figure 3.2.



图 3.2 输入接口电路  
Figure 3.2 Input interface circuit

○ 注意：UMLP57 为 5V-24V 通用驱动器，因此信号控制端不串电阻。

Note: UMLP57 is a 5V-24V universal driver, so there is no resistor in the signal control terminal.

## 尺寸图 / Dimensions

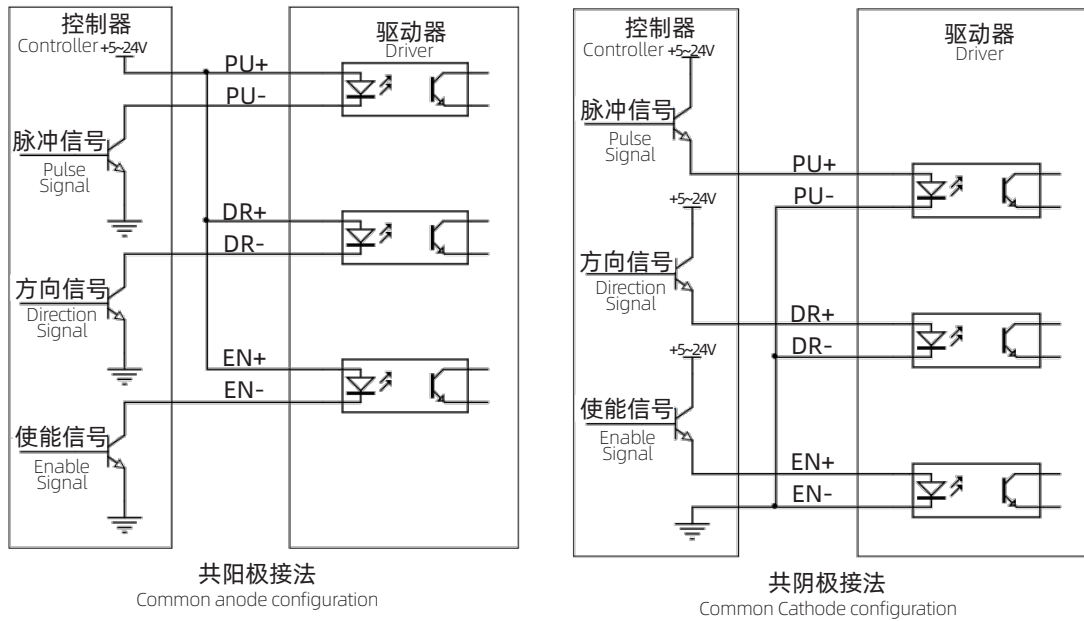
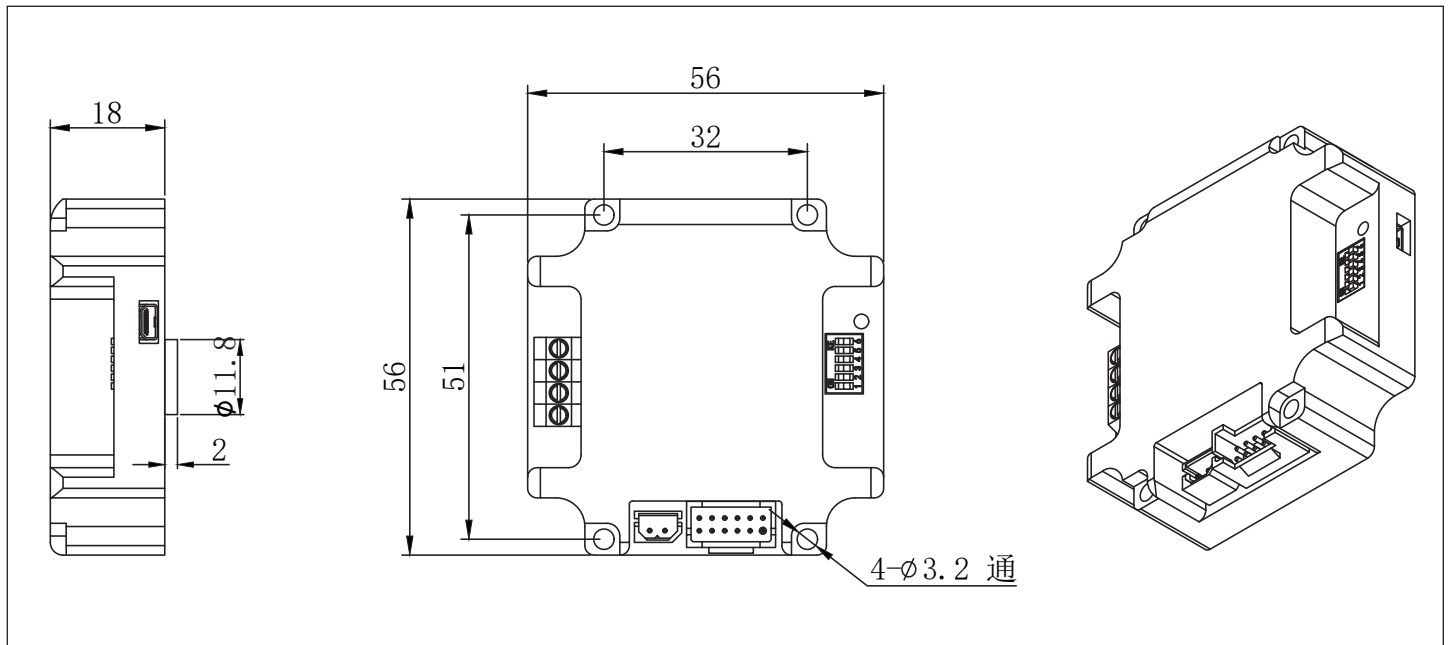

# 57 精密蜗轮蜗杆减速一体式步进电机 (闭环脉冲型)

57 Worm Geared Stepper Motor with Integrated Driver (Closed Loop Pulse Control)  
(Backlash ≤ 15 arcmin)

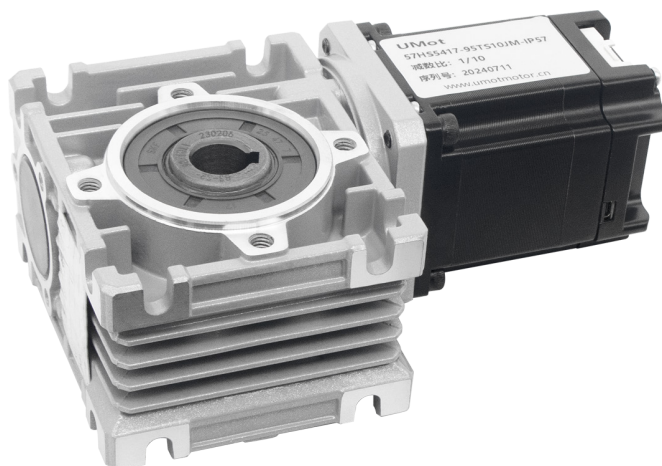

## 技术参数 / Technical Data

Model No.	额定电压 Rated Voltage (V)	每相电流 Current /Phase (A)	每相电阻 Resistance /Phase (Ω)	每相电感 Inductance /Phase (mH)	保持转矩 Holding Torque (mN.m)	引出线数 #of Leads	转动惯量 Rotor Inertia (g-cm <sup>2</sup> )	重量 Weight (kg)	机身长度 (L) Length(L) (mm)	适配减速比 Max. Gear Ratio
57HS5417	1.7	2.0	0.85	2.5	950	4	200	0.64	55	≤ 1: 80
57HS7407	2.1	3.0	0.7	2.0	1900	4	230	1.1	76	≤ 1: 80

## 减速电机性能参数 (57HS5417) / Geared Stepper Motor Specifications

减速比 Reduction Ratio	5	7.5	10	15	20	25	30	40	50	60	80
减速电机输出扭矩 Torque For Gearbox(mN.m)	4085	5985	7695	10830	13680	15913	18240	20000	18000	17000	15000
减速电机总高度 Total Length(mm)	168										
减速电机总重量 Total Weight(g)	1910										
减速器长度 Gearbox Length(mm)	95										
减速后速度 Speed After Gearbox	180	120	90	60	45	36	30	22.5	18	15	11.25
背隙 (无负载时) Backlash At No-load	15' ~18'										
效率 Efficiency	86%	84%	81%	76%	72%	67%	64%	58%	54%	50%	44%

## 减速电机性能参数 (57HS7407) / Geared Stepper Motor Specifications

减速比 Reduction Ratio	5	7.5	10	15	20	25	30	40	50	60	80
减速电机输出扭矩 Torque For Gearbox(mN.m)	8170	11970	15390	20000	20000	23000	21000	20000	18000	17000	15000
减速电机总高度 Total Length(mm)	189										
减速电机总重量 Total Weight(g)	2370										
减速器长度 Gearbox Length(mm)	95										
减速后速度 Speed After Gearbox	180	120	90	60	45	36	30	22.5	18	15	11.25
背隙 (无负载时) Backlash At No-load	15' ~18'										
效率 Efficiency	86%	84%	81%	76%	72%	67%	64%	58%	54%	50%	44%

# 尺寸图 / Dimensions

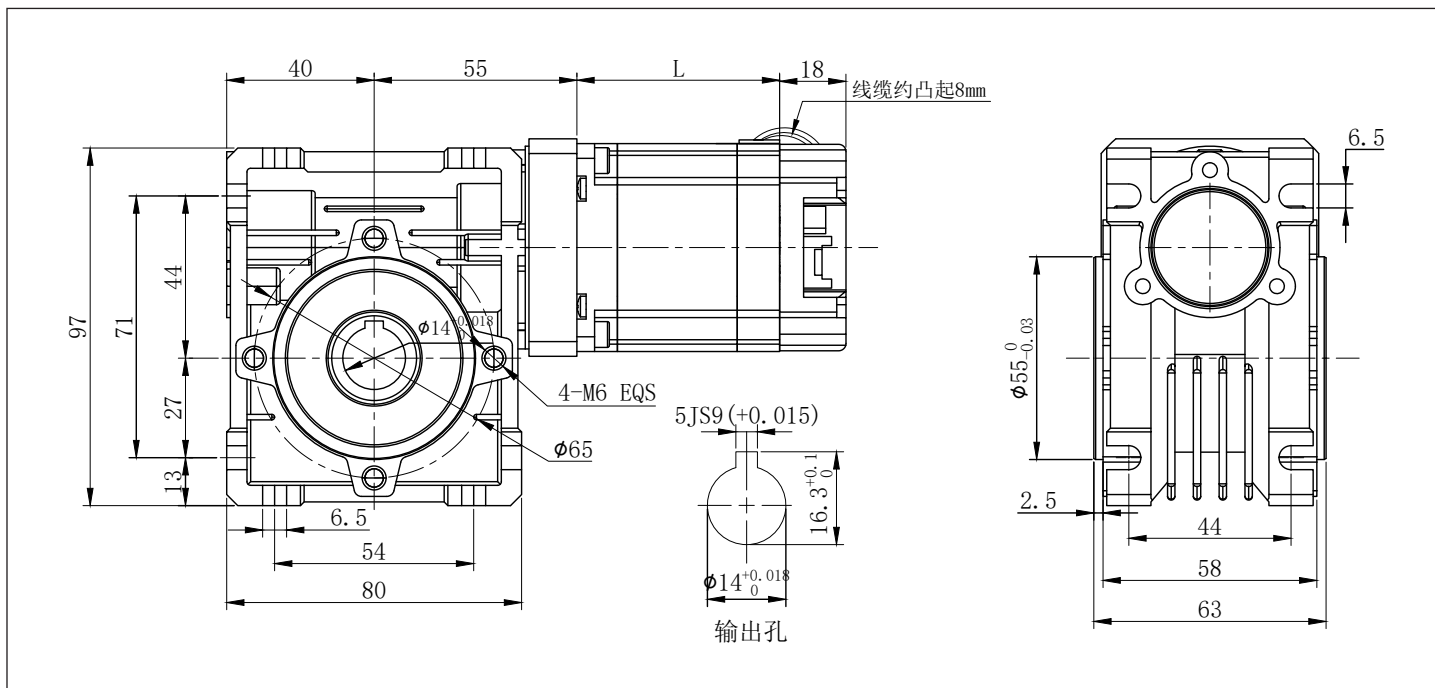

专  
心 · 专  
业 · 专  
注



 微信搜一搜

 umot优摩特



+86 2386132606



www.umotmotor.cn



info@umottech.com



重庆市九龙坡区火炬大道101号2110号