

符合RoHS指令要求
CONFORM TO RoHS DNSTRUCTIONS

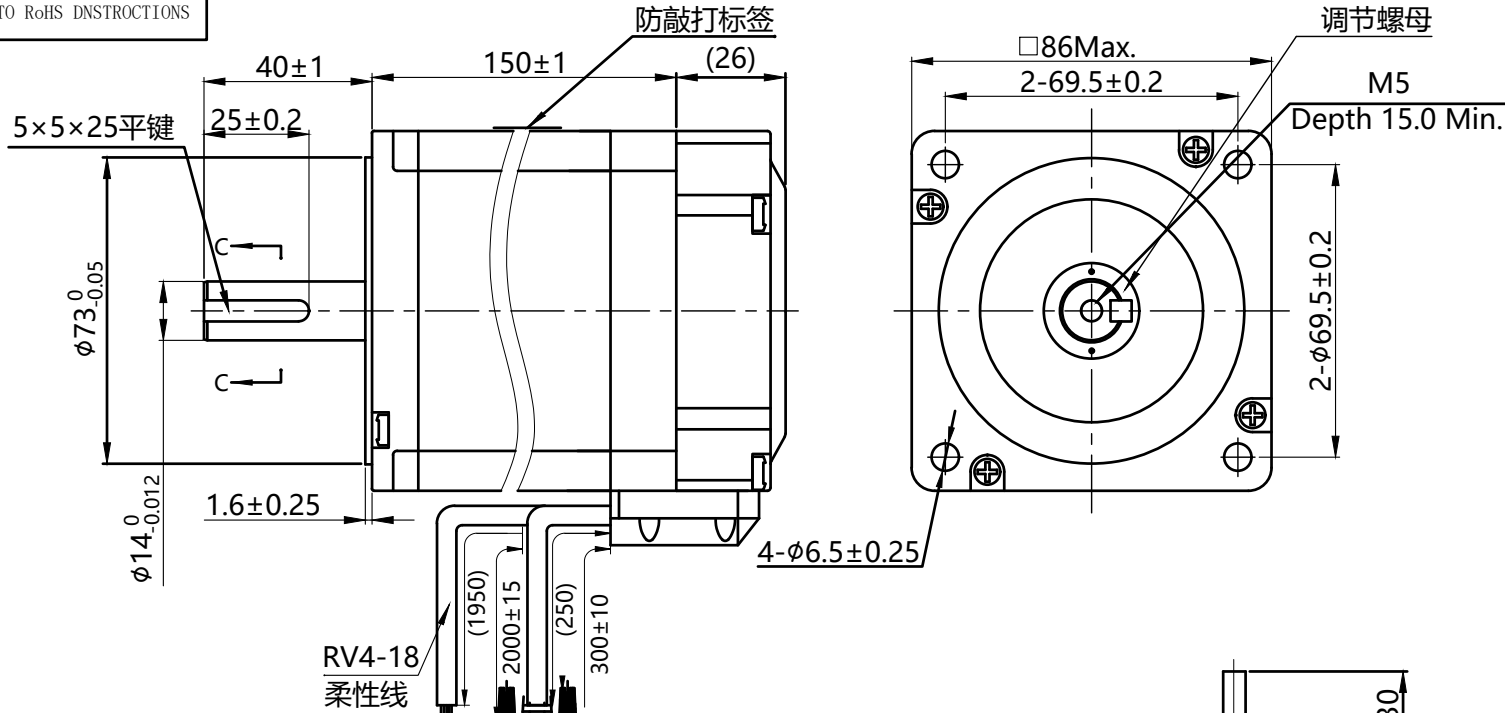

电气原理图

Wiring Diagram

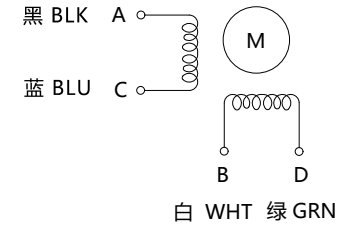

励磁顺序vs.旋转方向

Exciting Sequence vs. Direction of Rotation

STEP	A	B	C	D	
1	+	+	-	-	
2	-	+	+	-	
3	-	-	+	+	
4	+	-	-	+	

从安装面看为顺时针方向

Clockwise view from mounting side

编码器连接器针位/引线颜色

Encoder Pin No.vs.Lead wire color

颜色 Color	电压输出 TTL	DB15头 针位Pin No.
黄/YEL	B+	11
黑/BLK	A+	1
红/RED	Vcc	2
绿/GRN	B-	12
蓝/BLU	A-	13
白/WHT	GND	3

特性 character	规格 specifications
1. 相数 Number of phase	2
2. 步距角 Step Angle	1.8° ±0.5
3. 额定电压 Rated Voltage	DC 3.0V
4. 额定电流 Rated current	DC 6A
5. 保持转矩 Holding Torque	≥ 12N.m
6. 相电阻 Winding resistance	0.69±10% ohm(20°C)
7. 相电感 Winding inductaoce	7.2±20% mH (1kHz)
8. 转向(轴伸向看) Directlon of rotation	A-AB-B-CW
9. 转动惯量 Rotor Inertia	5400g.cm ²
10. 电机重量 Weight	6Kg
11. 绝缘等级 Insulation class	B Class

				视图 view			
				比例 inverse proportion	1:1		
				A0			
标记 REV	修改内容 Description	日期 Date	设计 INSPECTED	审核 CHECKED	批准 APPROVED	日期 Date	版本 version

重庆优摩特科技有限公司 Chongqing UMot technology Co.Ltd.		型号 Model	86SS150460-40J5-2000Y
--	--	-------------	-----------------------