

符合RoHS指令要求  
CONFORM TO RoHS DNSTRUCTIONS

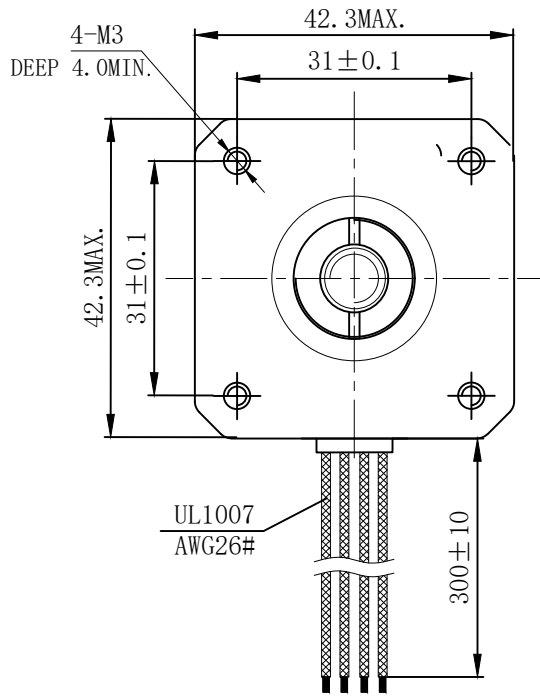

特性 character	规格 specifications
1. 螺杆导程 Screw lead	8mm
2. 步长 Step	0.04mm/step
3. 相数 Number of phase	2
4. 步距角 Step Angle	1.8°
5. 额定电压 Rated Voltage	DC 2.8V
6. 额定电流 Rated current	DC 1.68A
7. 保持转矩 Holding Torque	$\geq 400 \text{ mN} \cdot \text{m}$
8. 相电阻 Winding resistance	$1.65 \pm 15\% \text{ ohm (20}^\circ\text{C)}$
9. 相电感 Winding inductaoce	$3.3 \pm 20\% \text{ mH (1kHz)}$
10. 转向 (轴伸向看) Directlon of rotation	A-AB-B-CW
11. 转动惯量 Rotor Inertia	40 g.cm <sup>2</sup>
12. 电机重量 Weight	0.6Kg
13. 绝缘等级 Insulation class	B Class

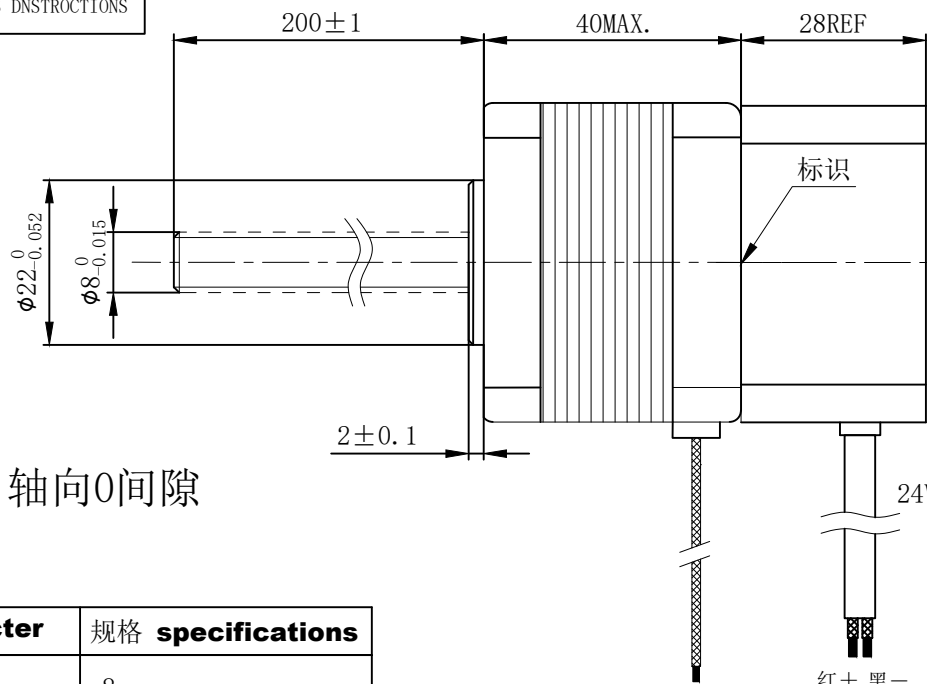
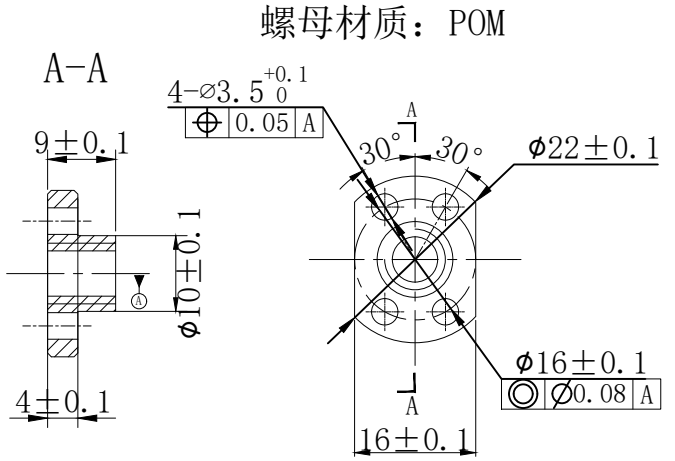

螺母材质: POM

黑绿红蓝  
ACBD

电气原理图  
winding drawing

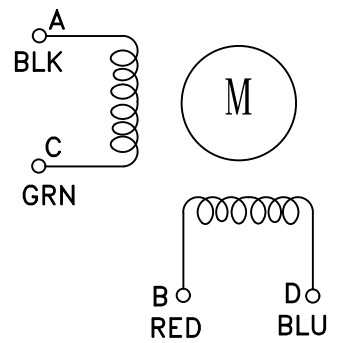

				<b>UMot</b>		视图 view		比例 inverse proportion		重庆优摩特科技有限公司 Chongqing UMot technology Co.Ltd.	
						1:1		A0			
标记 REV	修改内容 Description	日期 Date	设计 INSPECTED	审核 CHECKED	批准 APPROVED	日期 Date	版本 version	型号 Model	42HSC4409-200N8SC-300		