

符合ROHS指令要求
CONFORM TO ROHS DIRECTICTIONS

滑台机械限位20.5mm

100

滑台机械限位20.5mm

141

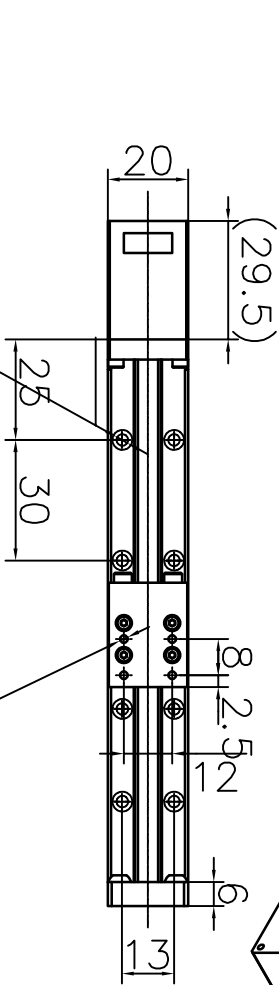
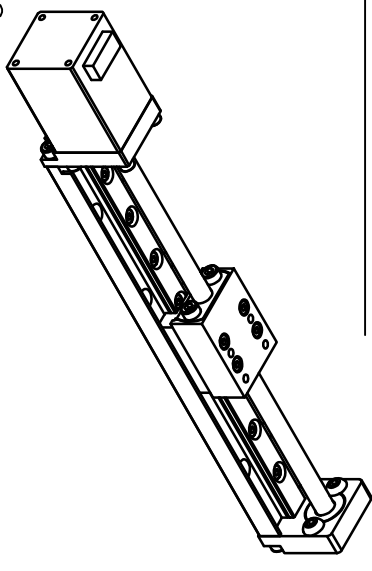
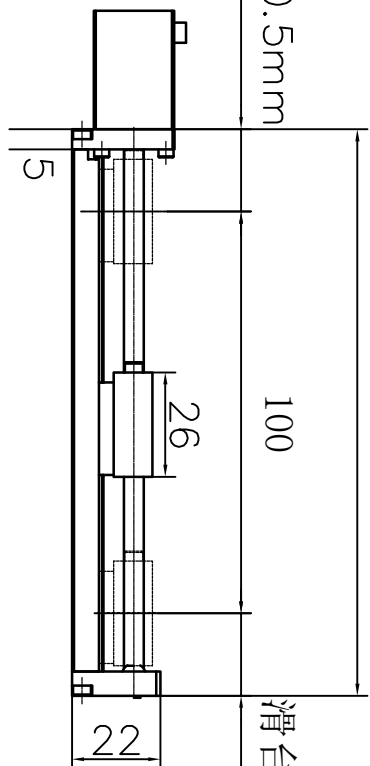

8- ϕ 2.9
 \square ϕ 5 \downarrow 2.6
4-M2.5 \downarrow 5

特性 character 规格 specifications

1. 相数 Number of phase	2
2. 步距角 Step Angle	1.8°
3. 额定电压 Rated Voltage	DC 3.9V
4. 额定电流 Rated current	DC 0.5A
5. 保持转矩 Holding Torque	\geq 18mN.m
6. 相电阻 Winding resistance	6.5 \pm 10% ohm(20°C)
7. 相电感 Winding inductance	1.5 \pm 20% mH (1kHz)
8. 转向(轴伸向看) Direction of rotation	A-AB-B-CW
9. 转动惯量 Rotor Inertia	2 g.cm ²
10. 电机重量 Weight	0.06kg
11. 绝缘等级 Insulation class	B Class

标记 RBV	修改内容 Description	日期 Date	设计 INSPECTED	审核 CHECKED	批准 APPROVED	日期 Date	版本 Version	型号 Model
							A0	SW-20-L100-T02-20

UMot

视图
View
比例
Inverse
proportion
1:1

重庆优摩特科技有限公司
Chongqing UMot technology Co. Ltd.

7

2

3

4

5

6