

符合RoHS指令要求
CONFORM TO RoHS DNSTRUCTIONS

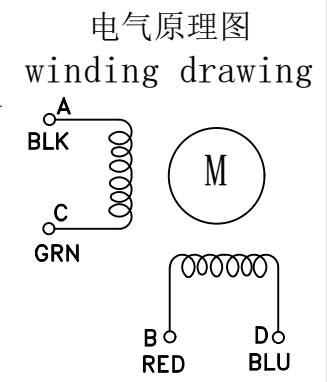
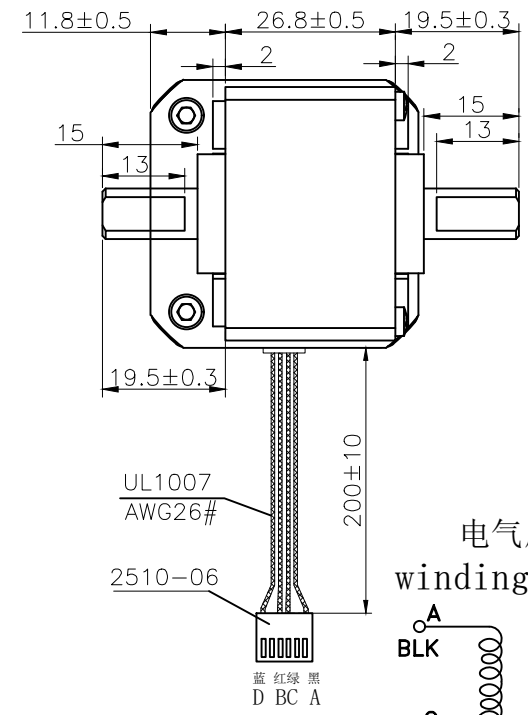
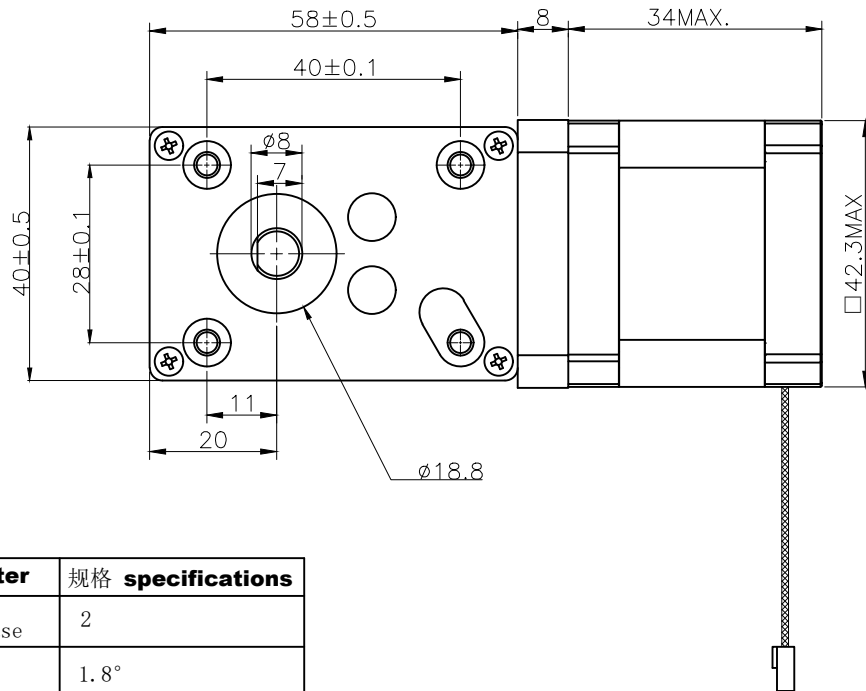

减速比: 17 31 50
100 290 505

特性 character	规格 specifications
1. 相数 Number of phase	2
2. 步距角 Step Angle	1.8°
3. 额定电压 Rated Voltage	DC 2.93V
4. 额定电流 Rated current	DC 1.33A
5. 保持转矩 Holding Torque	≥ 270mN.m
6. 相电阻 Winding resistance	2.2 ± 15% ohm (20°C)
7. 相电感 Winding inductance	3.5 ± 20% mH (1kHz)
8. 转向 (轴伸向看) Direction of rotation	A-AB-B-CW
9. 转动惯量 Rotor inertia	30 g.cm ²
10. 电机重量 Weight	0.22Kg
11. 绝缘等级 Insulation class	B Class

				UMot		视图 view		重庆优摩特科技有限公司 Chongqing UMot technology Co.Ltd.			
						比例 inverse proportion	1:1				
						A0					
标记 REV	修改内容 Description	日期 Date	设计 INSPECTED	审核 CHECKED	批准 APPROVED	日期 Date	版本 version	型号 Model	42HSC1409-58TS_J2-200		