

符合RoHS指令要求
CONFORM TO RoHS INSTRUCTIONS

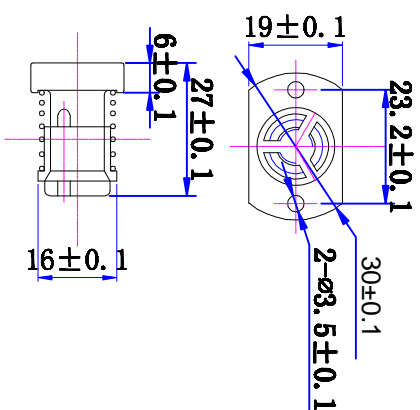

4-M3
DEEP 4.0min
UL2464
AWG22#

高柔屏蔽线

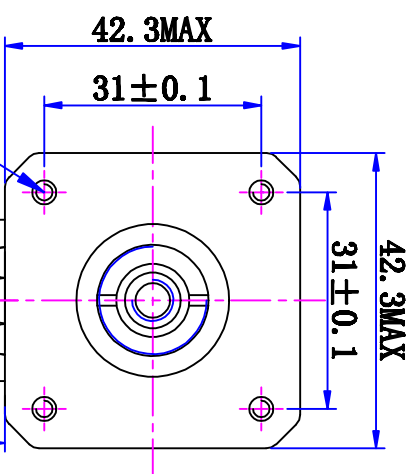
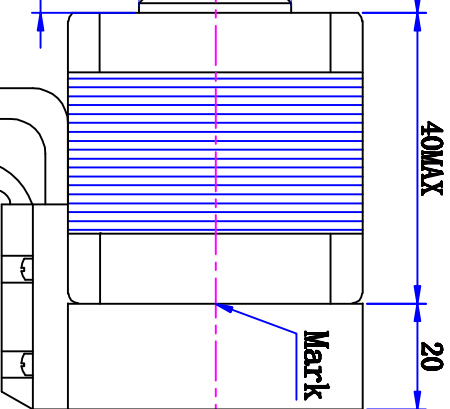
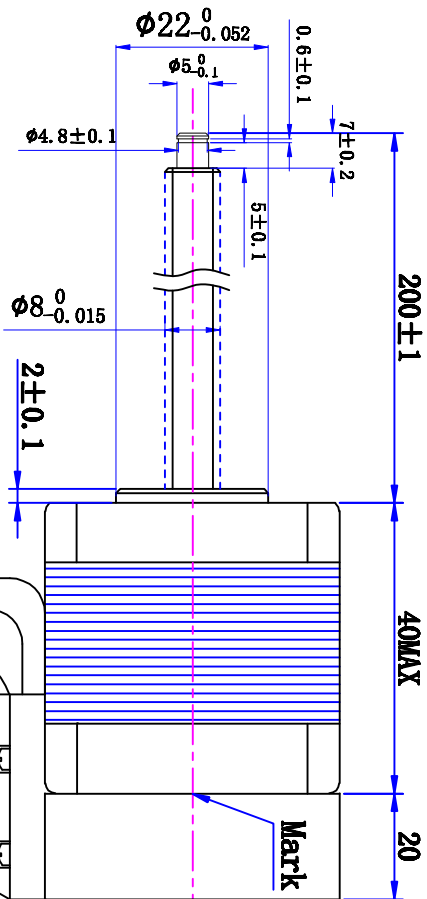
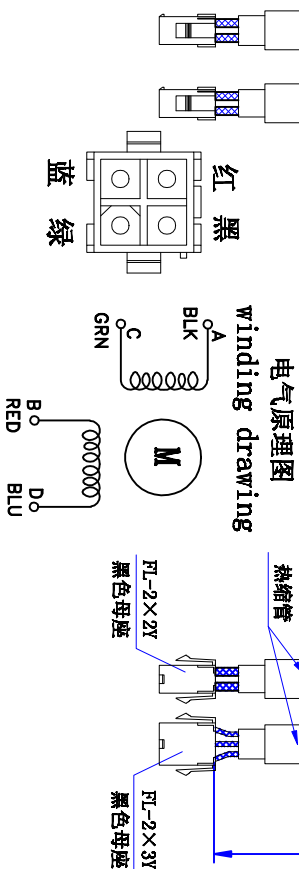
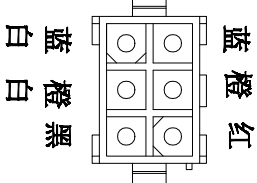

引出线 NO.	引出线 颜色	功能
1	红	输入+5V
2	黑	信号地
3	橙/白	编码器B-
4	橙	编码器B+
5	蓝\白	编码器A-
6	蓝	编码器A+

特性 character 规格 specifications

1. 螺杆导程 Screw Lead	4mm
2. 步长 Step	0.02mm/step
3. 相数 Number of phase	2
4. 步距角 Step Angle	1.8°
5. 额定电压 Rated Voltage	DC 2.8V
6. 额定电流 Rated current	DC 1.68A
7. 保持转矩 Holding Torque	≥ 450mN·m
8. 相电阻 Winding resistance	1.65±10% ohm (20°C)
9. 相电感 Winding inductance	3.3±20% mH (1kHz)
10. 转向 (旋转方向) Direction of rotation	A-AB-B-CW
11. 转动惯量 Rotor Inertia	40 g·cm ²
12. 电机重量 Weight	0.35Kg
13. 绝缘等级 Insulation class	B Class

标记 KEY	修改内容 Description	日期 Date
WJF	修正螺母外径	21/05/11

UMot

视图
View
比例
Inverse
proportion



1:1

重庆优摩特科技有限公司
Chongqing Umot technology Co., Ltd

设计 INSPECTED	审核 CHECKED	批准 APPROVED	日期 Date	版本 version
				A0

型号 Model	42SS4002-200N4-300
-------------	--------------------

D

C

B

A

1

2

3

4

5

6

1

2

3

4

5

6