

符合RoHS指令要求
CONFORM TO RoHS INSTRUCTIONS

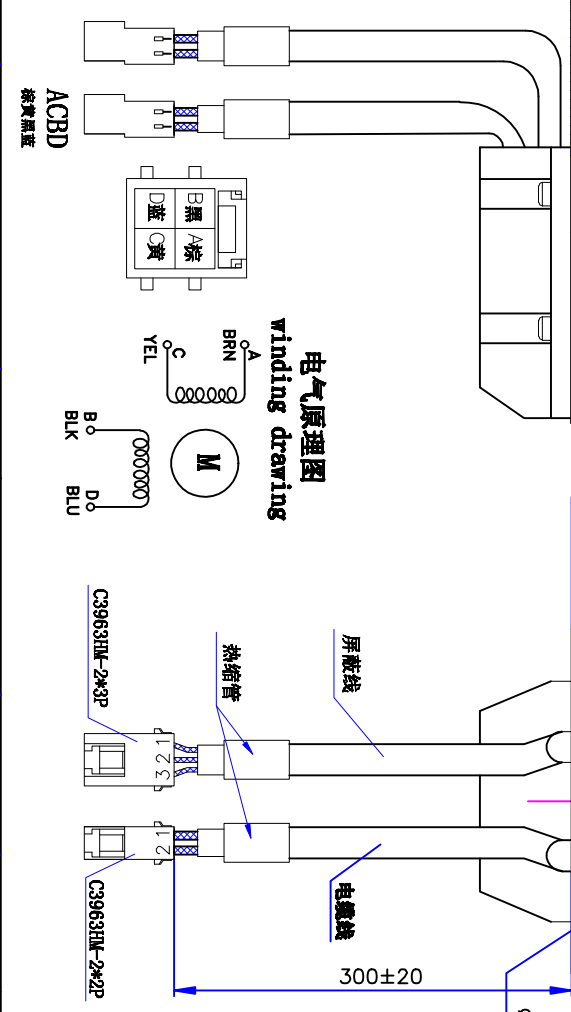
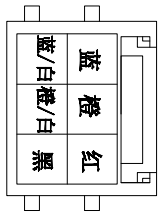
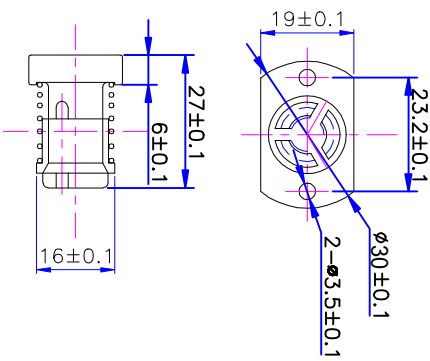
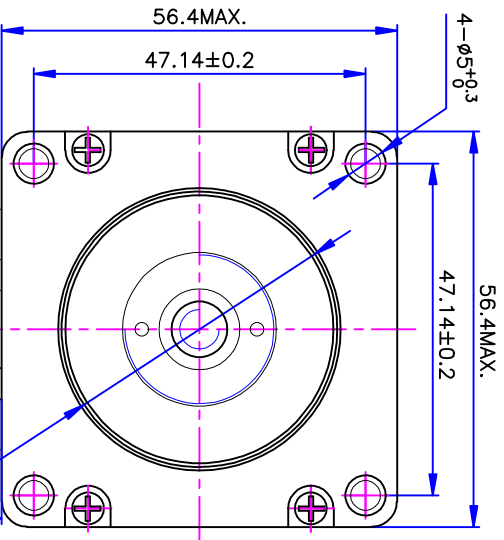
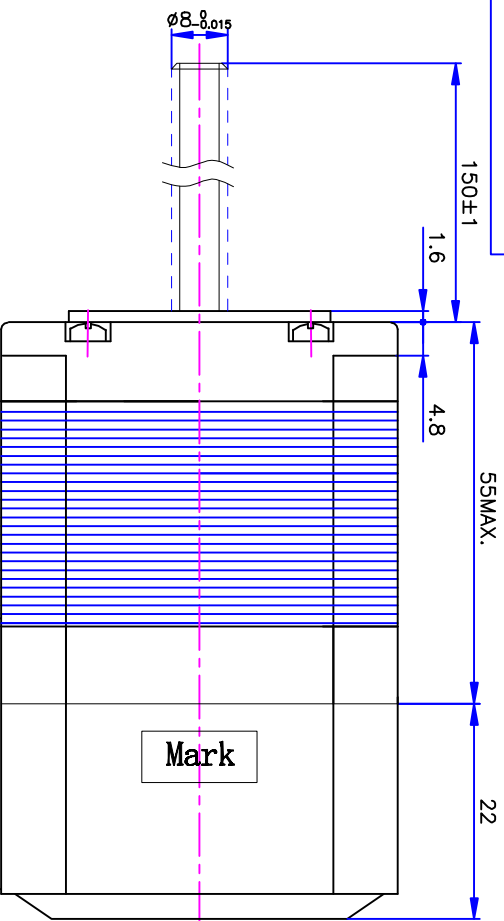

引出线 NO.	信号线颜色	功能
1	红	输入+5V
2	黑	信号地
3	橙/白	编码器B-
4	橙	编码器B+
5	蓝\白	编码器A-
6	蓝	编码器A+

特性 character	规格 specifications
1. 螺杆导程 Screw Lead	4mm
2. 步长 Step	0.02mm/step
3. 相数 Number of phase	2
4. 步距角 Step Angle	1.8°
5. 额定电压 Rated Voltage	DC 2.0V
6. 额定电流 Rated current	DC 4.0A
7. 保持转矩 Holding Torque	≥ 1200mN.m
8. 相电阻 Winding resistance	0.5±10% ohm (20°C)
9. 相电感 Winding inductance	2.0±20% mH (1KHz)
10. 转向 (旋转方向) Direction of rotation	A-AB-B-CW
11. 转动惯量 Rotor Inertia	200 g.cm ²
12. 电机重量 Weight	1.0Kg
13. 绝缘等级 Insulation class	B Class

标记 KEY	修改内容 Description	日期 Date
WJF	修正螺母外径	21/05/11

UMot

视图
View

比例
Inverse proportion

1 : 1

设计 INSPECTED	审核 CHECKED	批准 APPROVED	日期 Date	版本 version
				A0

重庆优摩特科技有限公司
Chongqing Umot technology Co., Ltd

型号 Model	57SST5405-150N4-300A
-------------	----------------------