

符合RoHS指令要求
CONFORM TO RoHS DNSTRUCTIONS

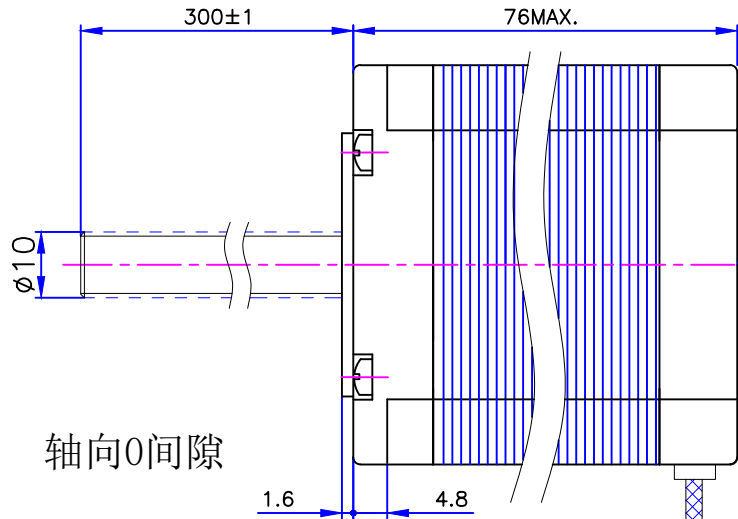

标识

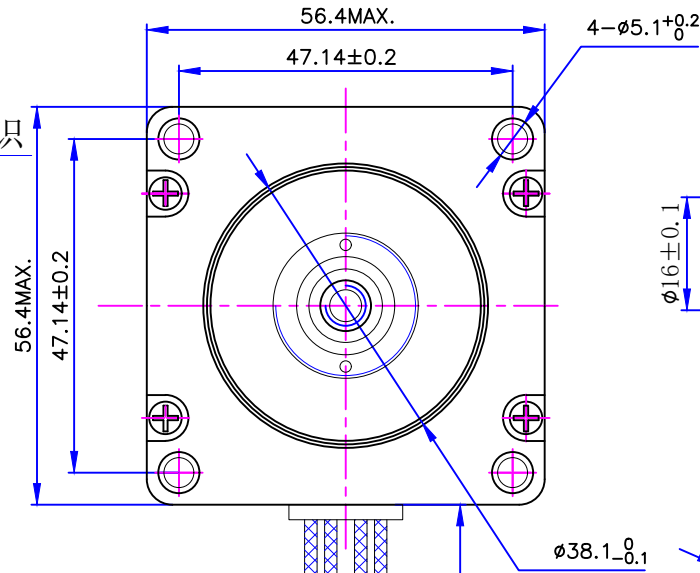

铜螺母:

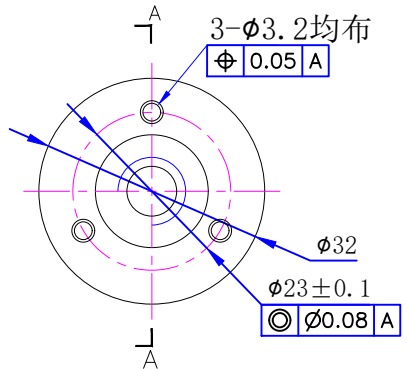
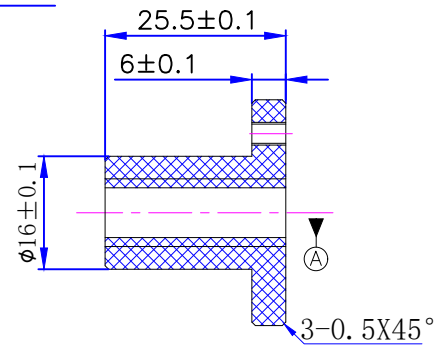

特性 character	规格 specifications
1. 螺杆导程 Screw lead	4mm
2. 步长 Step	0.02mm/step
3. 相数 Number of phase	2
4. 步距角 Step Angle	1.8°
5. 额定电压 Rated Voltage	DC 2.1V
6. 额定电流 Rated current	DC 3.0A
7. 保持转矩 Holding Torque	≥ 1900mN.m
8. 相电阻 Winding resistance	0.7±15% ohm(20°C)
9. 相电感 Winding inductance	2.0±20% mH (1kHz)
10. 转向 (轴伸向看) Direction of rotation	A-AB-B-CW
11. 转动惯量 Rotor Inertia	230 g.cm ²
12. 电机重量 Weight	1.1Kg
13. 绝缘等级 Insulation class	B Class

电气原理图
winding drawing

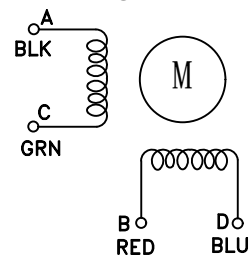

AC B D
黑绿红蓝

注意事项:

- 1、电机螺纹轴不得承受径向负载;
- 2、电机螺纹轴不能夹装或者受到硬物挤压, 以免发生变形及损坏螺牙;
- 3、使用期间有任何问题请与厂家联系, 请勿私自拆解电机;
- 4、电机必须轻拿轻放, 拿取时请拿电机本体, 勿手拎引出线、螺纹轴;
- 5、电机如需配油脂, 请与厂家联系。

UMot

视图
view

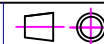

比例
inverse
proportion

1:1

重庆优摩特科技有限公司
Chongqing UMot technology Co.Ltd.

A0

标记 REV	修改内容 Description	日期 Date	设计 INSPECTED	审核 CHECKED	批准 APPROVED	日期 Date	版本 version	型号 Model
								57HS7407-300N4-500