

符合RoHS指令要求
CONFORM TO RoHS DNSTRUCTIONS

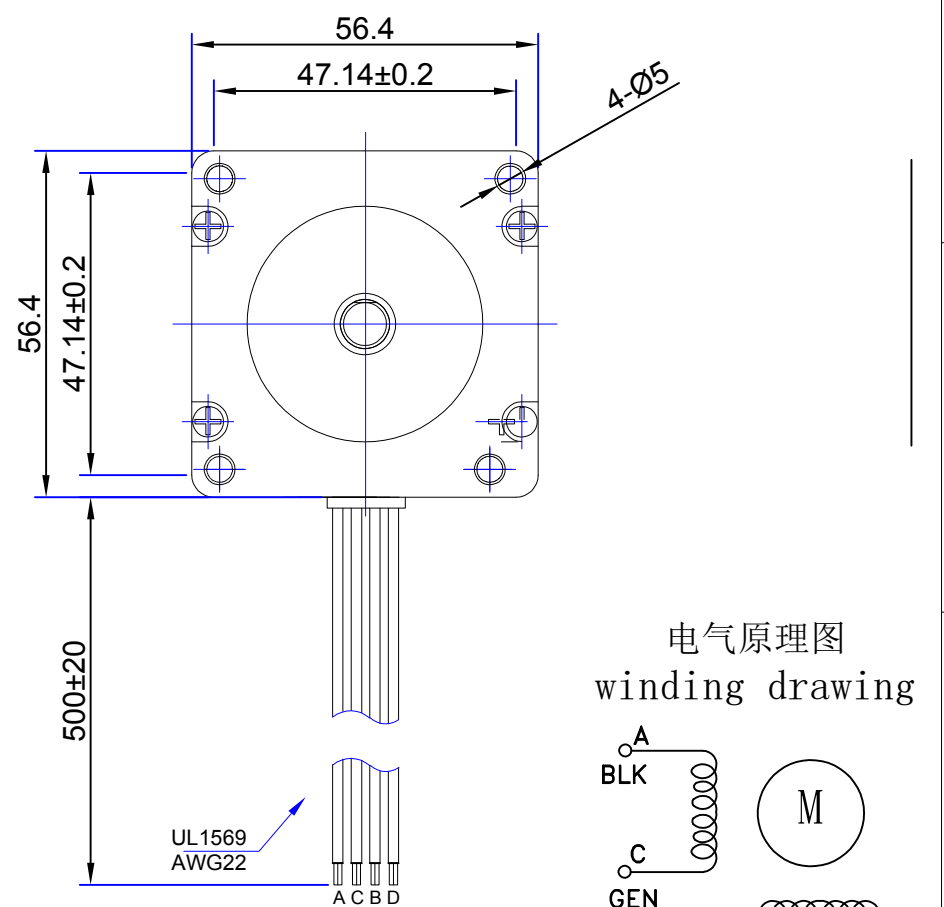

电气原理图
winding drawing

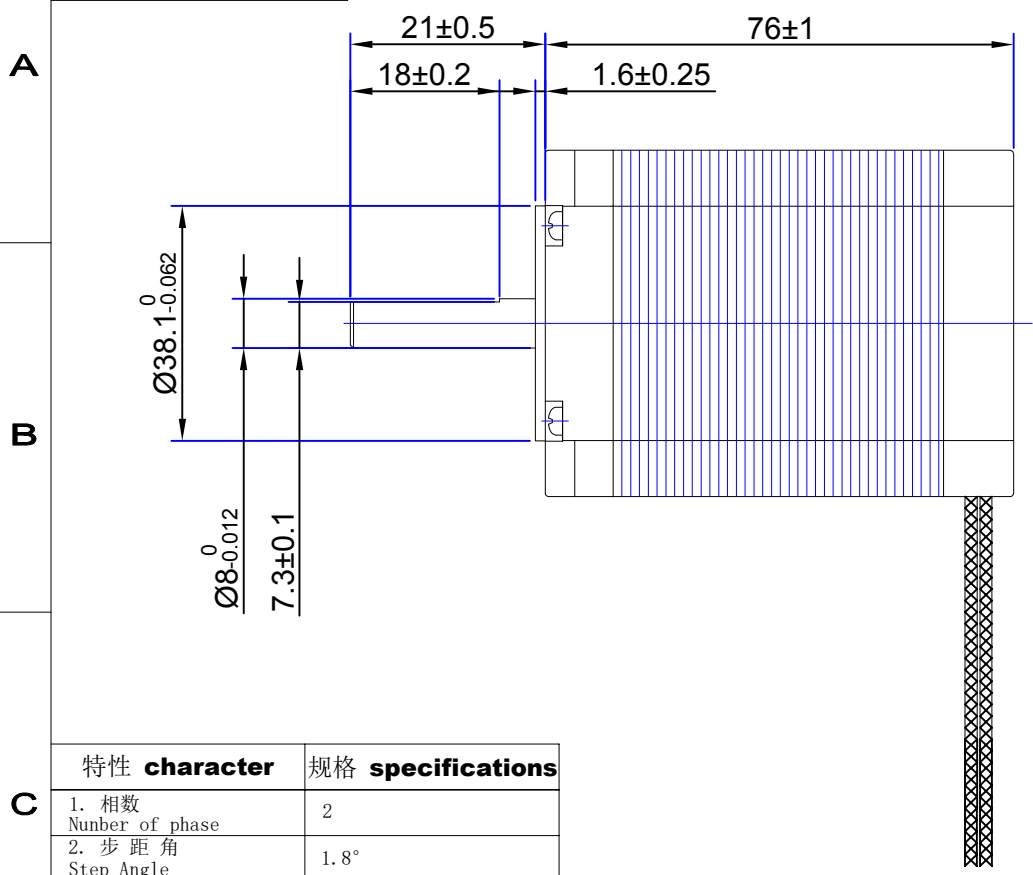
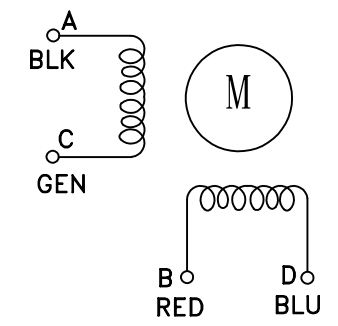

特性 character	规格 specifications
1. 相数 Number of phase	2
2. 步距角 Step Angle	1.8°
3. 额定电压 Rated Voltage	DC 2.64V
4. 额定电流 Rated current	DC 4.0A
5. 保持转矩 Holding Torque	≥ 2400mN.m
6. 相电阻 Winding resistance	0.66 ± 15% ohm(20℃)
7. 相电感 Winding inductance	2.3 ± 20% mH (1kHz)
8. 转向(轴伸向看) Direction of rotation	A-AB-B-CW
9. 转动惯量 Rotor Inertia	480g.cm ²
10. 电机重量 Weight	1.0 Kg
11. 绝缘等级 Insulation class	B Class

UMot				视图 view		重庆优摩特科技有限公司 Chongqing UMot technology Co.Ltd.			
				比例 inverse proportion	1:1				
				A0					
设计 INSPECTED	审核 CHECKED	批准 APPROVED	日期 Date	版本 Version	型号 Model	57HS7407-21B18-500Z			

标记 REV	修改内容 Description	日期 Date